

REVISION		
REV	DATE	DESCRIPTION
A	3/23/16	515693GCP - RELEASE MRY
B	9/6/16	516327ECP/D - CHG DATA SHEET REVISION MRY
C	6/6/17	517424ECP/D - REMOVE DATA SHEET REVISION MRY
D	9/5/17	517727ECP/D - ADD DIMENSION TOLERANCES MRY
E	3/25/19	520556ECP/D - ADD BLADE TOLERANCES MRY

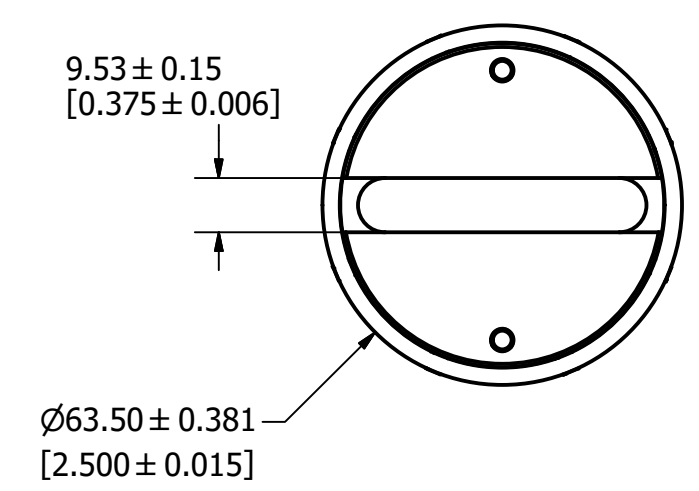
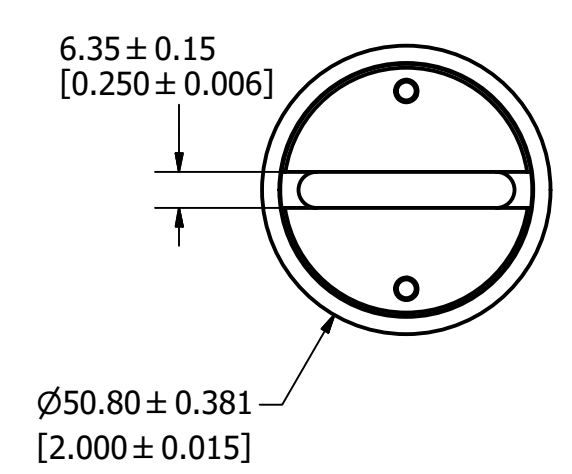
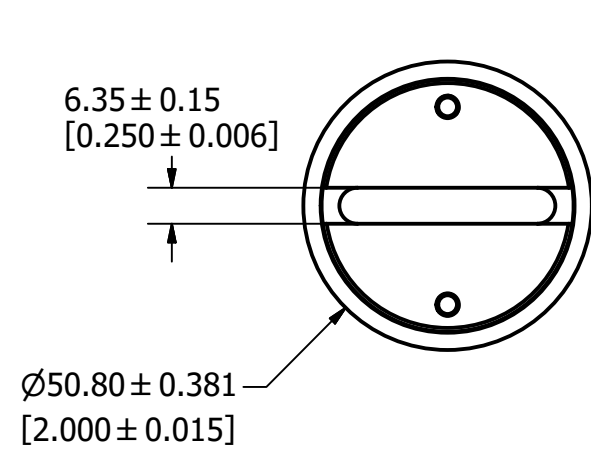
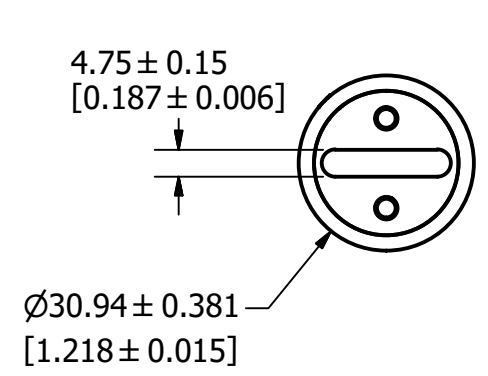
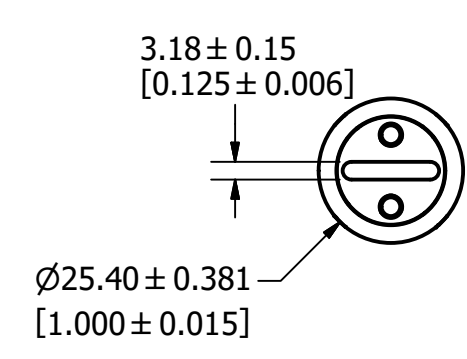
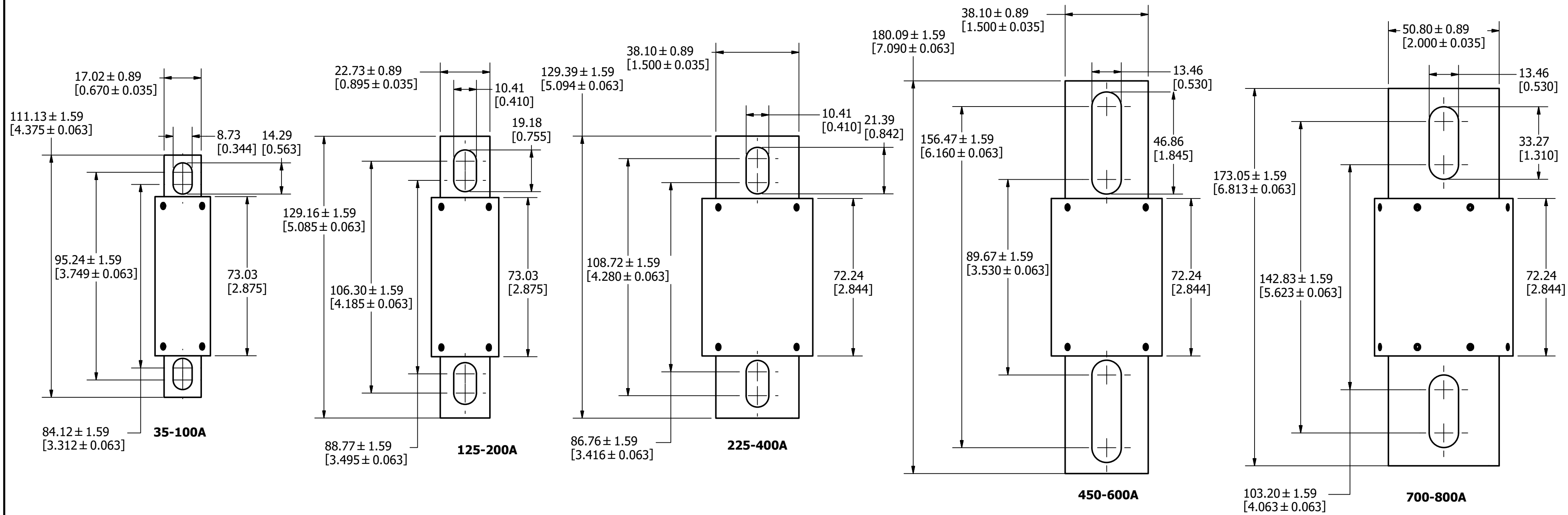

●	DENOTES CRITICAL CHARACTERISTICS.
CPK	DENOTES CPK DIMENSIONS, -MINIMUM CPK VALUE
(ST)	DENOTES A CHARACTERISTIC THAT PROVIDES AN INDICATION OF PROCESS PERFORMANCE. PROCEDURE FOR MEASUREMENT AND TRACKING TO BE DEFINED IN LITTELFUSE INSPECTION INSTRUCTIONS.
CP	DENOTES CP DIMENSIONS, -MINIMUM CP VALUE MUST BE WITHIN THE DIMENSIONAL LIMITATIONS SHOWN ON DRAWING AND INITIALLY LOCATED TO ALLOW FOR MAXIMUM TOOL LIFE.

MATL SPEC	FINISH		
DRW MYORK	DATE 9/3/2015	SCALE NTS	FINISH GOOD WT GRAMS/PIECE

UNLESS OTHERWISE SPECIFIED, DIMENSIONS ARE IN MILLIMETERS, DIMENSIONS IN BRACKETS [] ARE INCHES DIMENSIONING AND DO NOT INCLUDE PLATING. TOLERANCING TO BE INTERPRETED IN ACCORDANCE WITH ANSI Y14.5M-1994

3RD ANGLE PROJECTION

TITLE L70QS SERIES OUTLINE