

# AB BULLETIN 1406 TO MPS MOTOR PROTECTION SYSTEM RETROFIT

The MPS Motor Protection System is an excellent choice as a replacement for the AB Bulletin 1406 Motor Protector due to similarities in modular design and terminal layout. While the MPS can be programmed to simulate the AB-1406, it can also add protective features, control, metering, data logging, and communications.

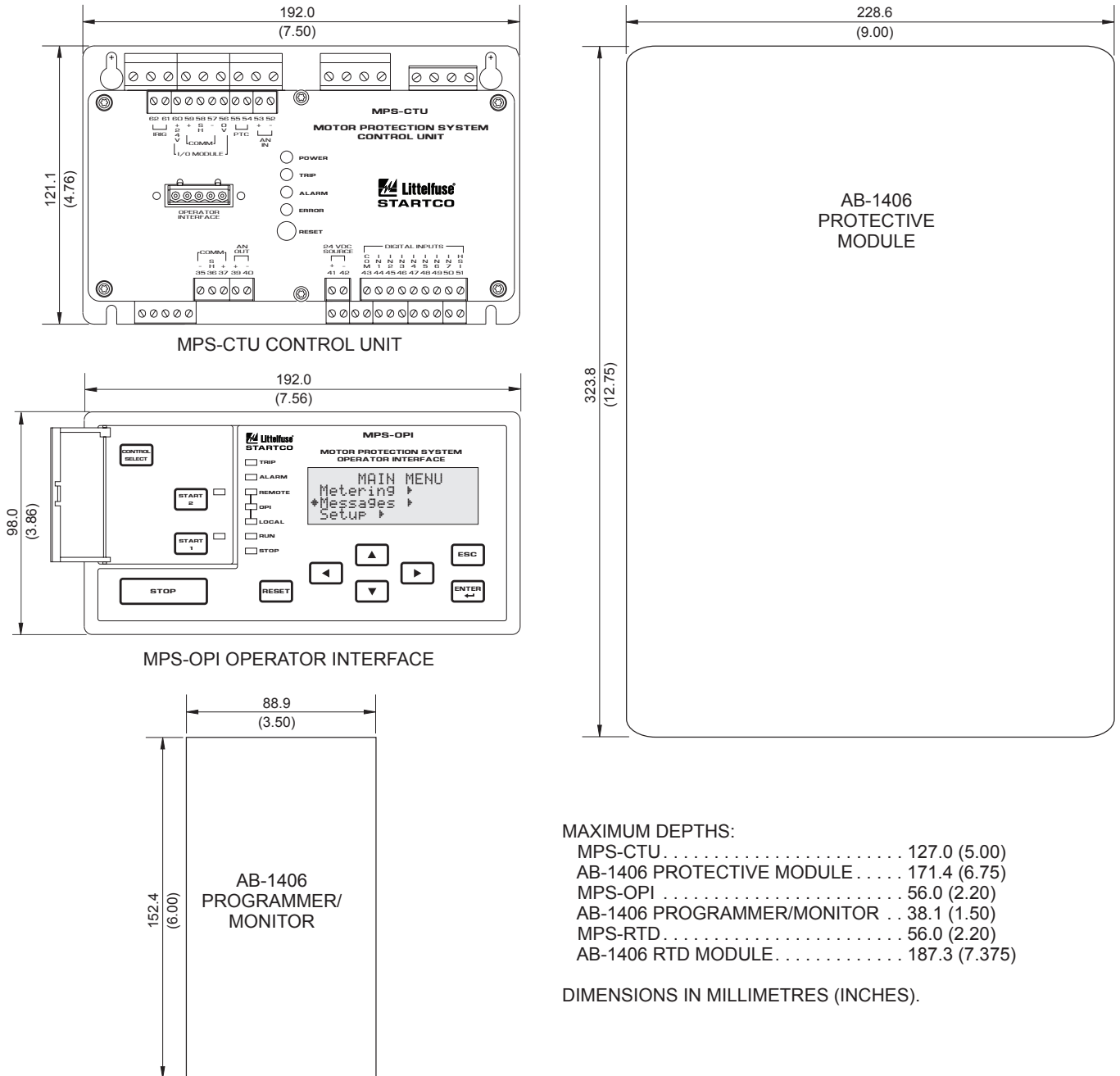

MAXIMUM DEPTHS:

MPS-CTU	127.0 (5.00)
AB-1406 PROTECTIVE MODULE	171.4 (6.75)
MPS-OPI	56.0 (2.20)
AB-1406 PROGRAMMER/MONITOR	38.1 (1.50)
MPS-RTD	56.0 (2.20)
AB-1406 RTD MODULE	187.3 (7.375)

DIMENSIONS IN MILLIMETRES (INCHES).

Figure 1A: Physical Dimensions

### AB BULLETIN 1406 TO MPS MOTOR PROTECTION SYSTEM RETROFIT

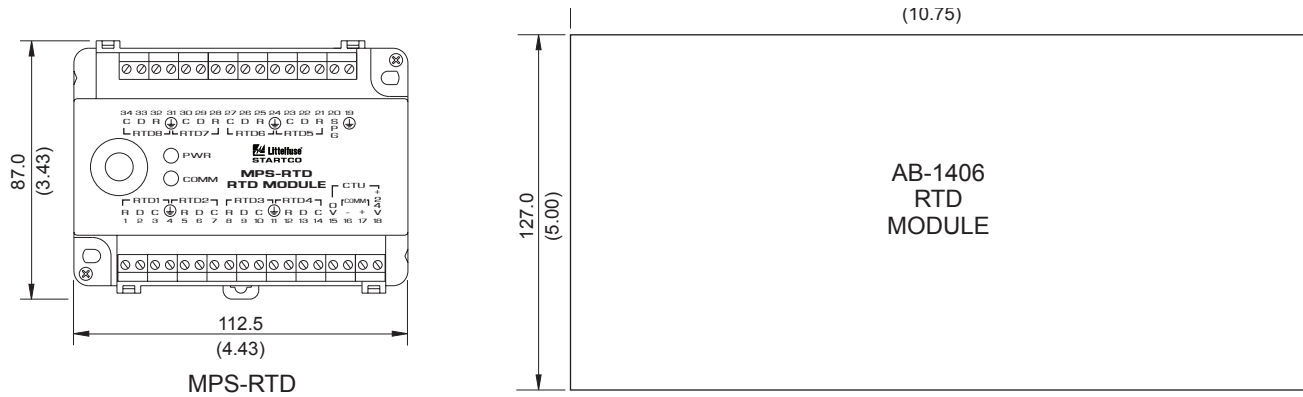

Figure 1B: Physical Dimensions

When the MPS-CTU Control Unit is mounted as shown below, its terminal locations are very similar to the AB-1406. Physical orientation does not affect performance.

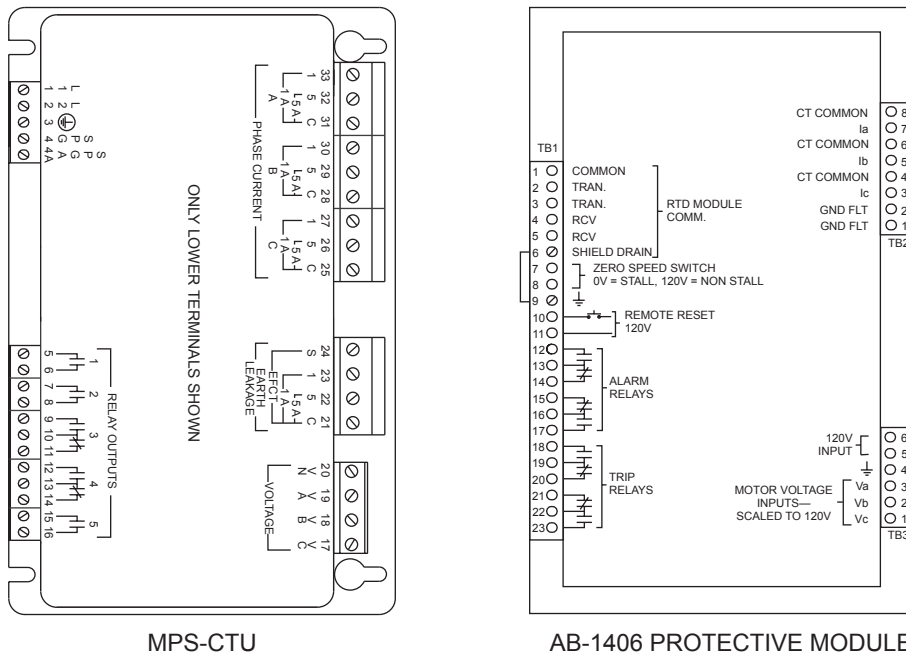

Figure 2: Terminal Layouts (not to scale)

## AB BULLETIN 1406 TO MPS MOTOR PROTECTION SYSTEM RETROFIT

Before the AB-1406 is removed from service, the following information should be recorded. Use this table as a guideline when programming the MPS to mimic an AB-1406.

AB-1406 Function #	Description	MPS-OPI Menu Location
1:	Phase CT primary rating (A)	Setup / System Ratings / CT Primary
2:	Full load current FLA (A)	Setup / System Ratings / FLA Rating
3:	Locked rotor current (A)* * MPS is set as (x FLA)	Setup / Protection / Overload / LR Current
4:	Line-to-Line voltage (V)* * AB-1406 uses 2 PT method	Setup / System Ratings / System Voltage Setup / System Ratings / V Connection
5, 6:	NOT REQUIRED	
7:	Locked rotor time, cold (s) <i>Locked rotor time, hot = 0 s</i>	Setup / Protection / Overload / LR Time Cold Setup / Protection / Overload / LR Time Hot
8:	Allowable Acceleration Time(s)* * Zero speed switch input required	Setup / Digital Inputs / Digital Input 2 / In 2 Bypass Delay
9: <sup>1</sup>	Number of starts per time increment	Setup / Protection / Starts/hour / # Starts/hour
10: <sup>1</sup>	Time increment (hours)	Setup / Protection / Starts/hour / Time between
11:	Phase unbalance (%FLA) <i>Phase unbalance delay = 2 s</i> <i>Phase unbalance alarm = 90% Trip Level</i>	Setup / Protection / Unbalance (I) / Trip Level Setup / Protection / Unbalance (I) / Trip Delay Setup / Protection / Unbalance (I) / Alarm Level
12:	Phase reversal protection (enable / disable)	Setup / Protection / Phase Reverse (I)
13:	Undervoltage (% line V)	Setup / Protection / Undervoltage / Trip Level
14:	Undervoltage trip delay (s)	Setup / Protection / Undervoltage / Trip Delay
15:	Ground-fault CT primary rating (A)	Setup / System Ratings / EF-CT Primary
16:	Ground-fault alarm level (A)* <i>Ground-fault alarm delay = 0 s</i>	Setup / Protection / Earth Fault / Alarm Level Setup / Protection / Earth Fault / Alarm Delay
17:	Ground-fault trip level (A)*	Setup / Protection / Earth Fault / Trip Level
18:	Ground-fault trip delay (ms) * MPS is set as (x EFCT primary)	Setup / Protection / Earth Fault / Trip Delay
19:	Low level fault current (x FLA)	Setup / Protection / Overcurrent / Trip Level
20:	Jam (x FLA)	Setup / Protection / Jam / Trip Level
21:	Trip inhibit (enable / disable)* * MPS provides Aux. Overcurrent Setpoint	Setup / Protection / Aux. Overcurrent
22:	Underload (%FLA)	Setup / Protection / Undercurrent / Trip Level
23:	Underload trip delay (s)	Setup / Protection / Undercurrent / Trip Delay
24:	Ultimate Trip Current (x FLA)	Setup / System Ratings / Service Factor
25:	Winding alarm temperature (°C)	Setup / Protection / RTD temperature
26:	Winding trip temperature (°C)	RTD type, function, and trip and alarm setpoints are programmable for each RTD
27:	Bearing alarm temperature (°C)	
28:	Bearing trip temperature (°C)	
29+:	NOT REQUIRED	

TABLE : Setup Information.

<sup>1</sup> The MPS is programmed with a value for the maximum number of starts in one hour, and with a value for the minimum time between consecutive starts. The AB-1406 is programmed with a value for the maximum number of starts in a programmable time interval. These values are similar but not interchangeable.

## AB BULLETIN 1406 TO MPS MOTOR PROTECTION SYSTEM RETROFIT

In the MPS-OPI menu location *Setup / Relay Outputs / Relay x*, assign Output Relay 3 the *Alarm1* function, Output Relay 4 the *Trip1* function, and select *Fail-Safe* or *Non-Fail-Safe* operating mode. This allows the MPS output relays to mimic the AB-1406 output relays. There are many additional protective functions provided with the MPS that are not listed in Table 1. The MPS manual, available at [www.startco.ca](http://www.startco.ca), describes each additional feature in detail.

Install the MPS following the wiring guidelines shown in Fig. 3. These guidelines assume a typical installation of the AB-1406 Motor Protector. If remote reset and zero speed switch inputs are required, connect them to Digital Input 1 and Digital Input 2 on the MPS CTU. Program Digital Input 1 as *Reset* under *Setup / Digital Inputs / Digital Input 1 / Function*. Program Digital Input 2 as *Trip 1 (with delay)* under *Setup / Digital Inputs / Digital Input 2 / Function*. The *Bypass Delay* value is found in Table 1, listed under AB-1406 Function #8.

CAUTION – All guidelines involved in this document assume a typical installation of the AB-1406. All wiring and set points should be confirmed. Be sure to follow all proper safety procedures when accessing the wiring / terminals on these devices.

# AB BULLETIN 1406 TO MPS MOTOR PROTECTION SYSTEM RETROFIT

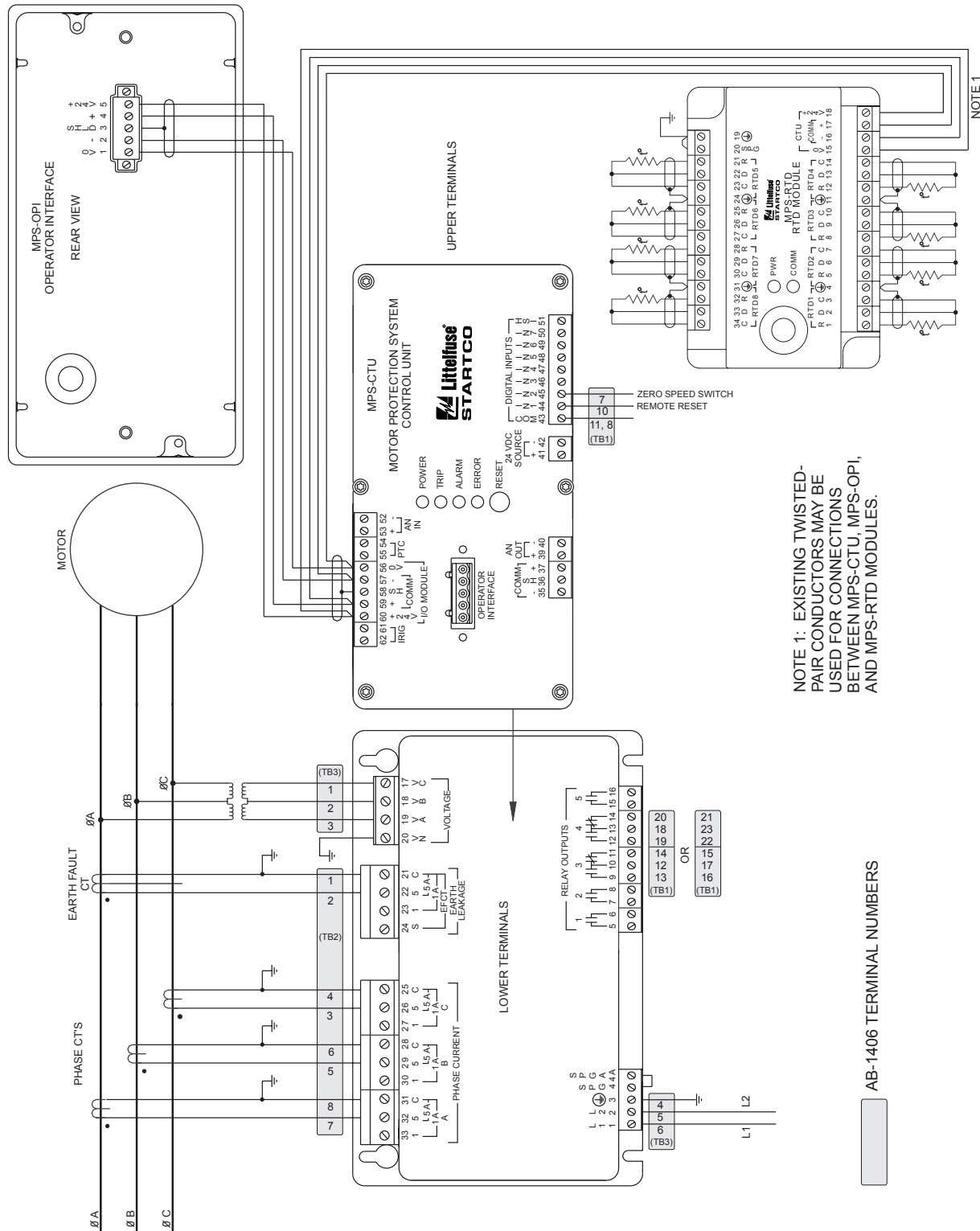

Figure 3: Installation