

PGR-6150 SERIES

Motor Protection System



Description

The PGR-6150 Motor Protection System provides 13 protective functions by utilizing both current and temperature inputs. It is a modular system consisting of the control unit and an operator interface (PGR-6150-OPI). The OPI allows programming and displays metered values. The PGR-6150 is used to provide current- and temperature-based protection, metering and data logging for three-phase motors used in industrial environments. Current transformers are not required for currents up to 25 A.

1 Control Unit

- Integrated phase CTs (external for applications > 25 A)
- Ground-fault CT input
- One PTC input and one programmable input
- Two programmable output contacts
- Eight status LEDs
- RS-485 Communications
- DIN-rail mountable
- PC interface software

A Operator Interface (optional)

- Large, bright, LCD display (2 x 20 alphanumeric characters)
- Keypad for menu selection (system parameters, measurements, and fault reports)
- Displays metered values
- Six user-programmable LEDs
- Powered by Control Unit
- 1 meter (39-inch) connection cable included

Simplified Circuit Diagram

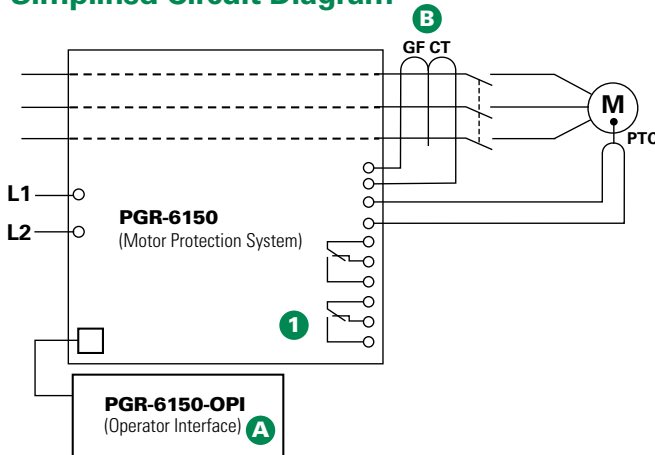

Accessories

- A PGR-6150-OPI Operator Interface**
Optional Operator Interface for displaying metered values and programming
- B PGC-6000 Series Ground-Fault Transformer**
Optional zero-sequence current transformer, used to measure ground-fault current. Required for applications >25 A.

Ordering Information

ORDERING NUMBER	CONTROL POWER
PGR-6150-24 (Control Unit)	24/48 Vdc
PGR-6150-120 (Control Unit)	120/240 Vac/dc
PGR-6150-OPI (Operator Interface)	Powered by Control Unit

NOTE: External CTs can be used for full-load currents >25 A.

ACCESSORIES	REQUIREMENT
PGC-6000 Series	Optional

PGR-6150 SERIES

Motor Protection System

Features & Benefits

FEATURES	IEEE #	BENEFITS
No CTs required	49, 51	No current transformers are required for currents < 25 A
Adjustable trip settings		Adjustable overload trip class setting from 5 to 45 to match motor characteristics
Digital input		Programmable digital input
Output contacts		Two programmable Form C output contacts for operation of separate annunciation and trip circuits
Overload	49, 51	Extends motor life and prevents insulation failures and fires
Overcurrent/Jam	50, 51	Detects catastrophic failures and fires; extends motor life
Undercurrent	37	Detects low level or no-load conditions
Unbalance (current)	46	Prevents overheating due to unbalanced phases
Phase loss/Phase sequence	46	Detects unhealthy supply conditions
PTC overtemperature	49	Detect high ambient or blocked ventilation and single phasing; prevents shaft/pump damage
Dynamic thermal model		Provides protection through starting, running, overload, and cooling cycles
Communications		RS-485 communications to remotely display metered values

Dynamic Thermal Modeling

Without Thermal Memory

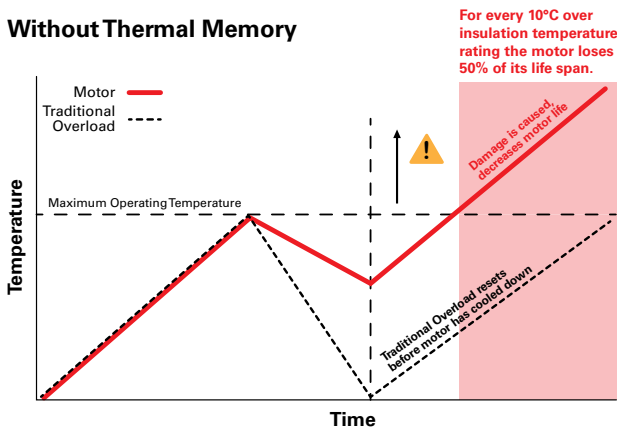

With Thermal Memory

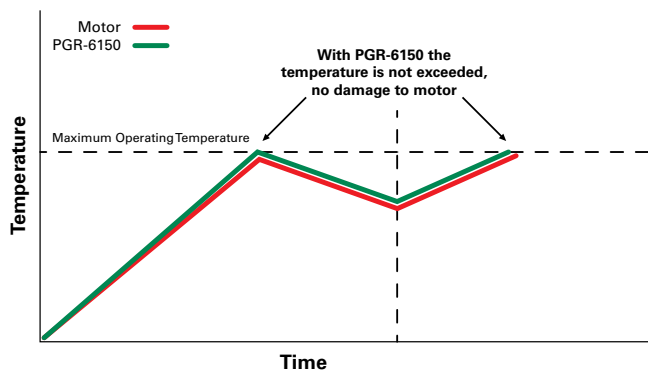

Wiring Diagram

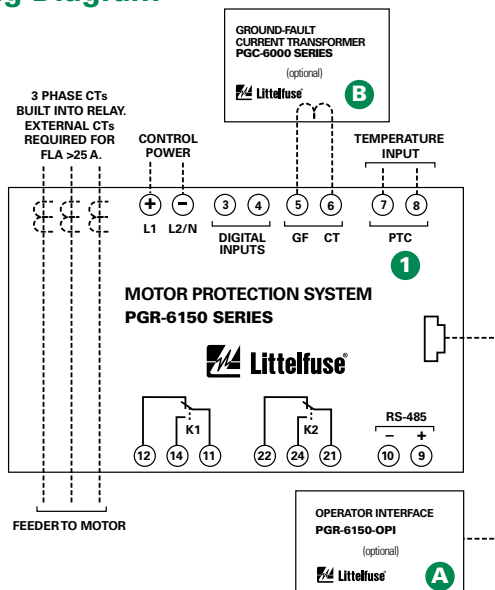

Specifications

Protective Functions (IEEE Device Numbers)	Overload (49, 51) Phase sequence (46) Overcurrent (50, 51) Jam Ground fault (50G/N, 51G/N) Undercurrent (37)	PTC overtemperature (49) Failure to accelerate RTD temperature (49) Unbalance (current) (46) Starts per hour (66) Phase loss (current) (46)
Input Voltage	110-230 Vac/Vdc; 24/48 Vdc, 5 W	
AC Measurements	RMS, 16 samples/cycle	
Frequency	50, 60 Hz	
Dimensions (Control Unit)	H 83 mm (3.3"); W 78 mm (3.1"); D 99 mm (3.9")	
Dimensions (Operator Interface)	H 56 mm (2.2"); W 106 mm (4.2"); D 22.8 mm (0.9")	
Output Contacts	Two Form C	
Communications	RS-485 with Modbus [®] RTU	
Approvals	UL Listed (E353735), CE (European Union)	
Warranty	5 years	
Mounting	DIN (Control Unit); Panel (Operator Interface)	