

PART NUMBER

OLD45951ZX

REVISION

REV	DATE	DESCRIPTION
A	3/11/24	527585GCP - RELEASE PER EM3406 MRY

SLOT 5.6 x 13.2 [0.22 x 0.52] THRU
CB 12.2 x 19.8 [0.48 x 0.78]

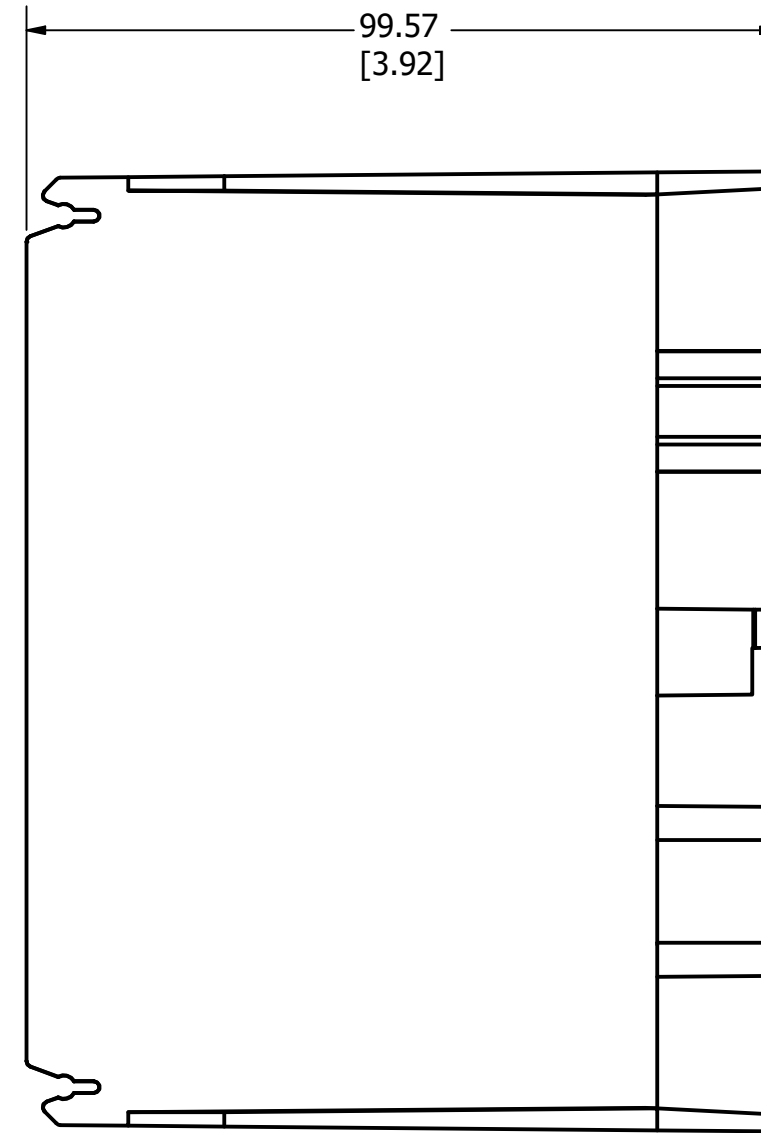
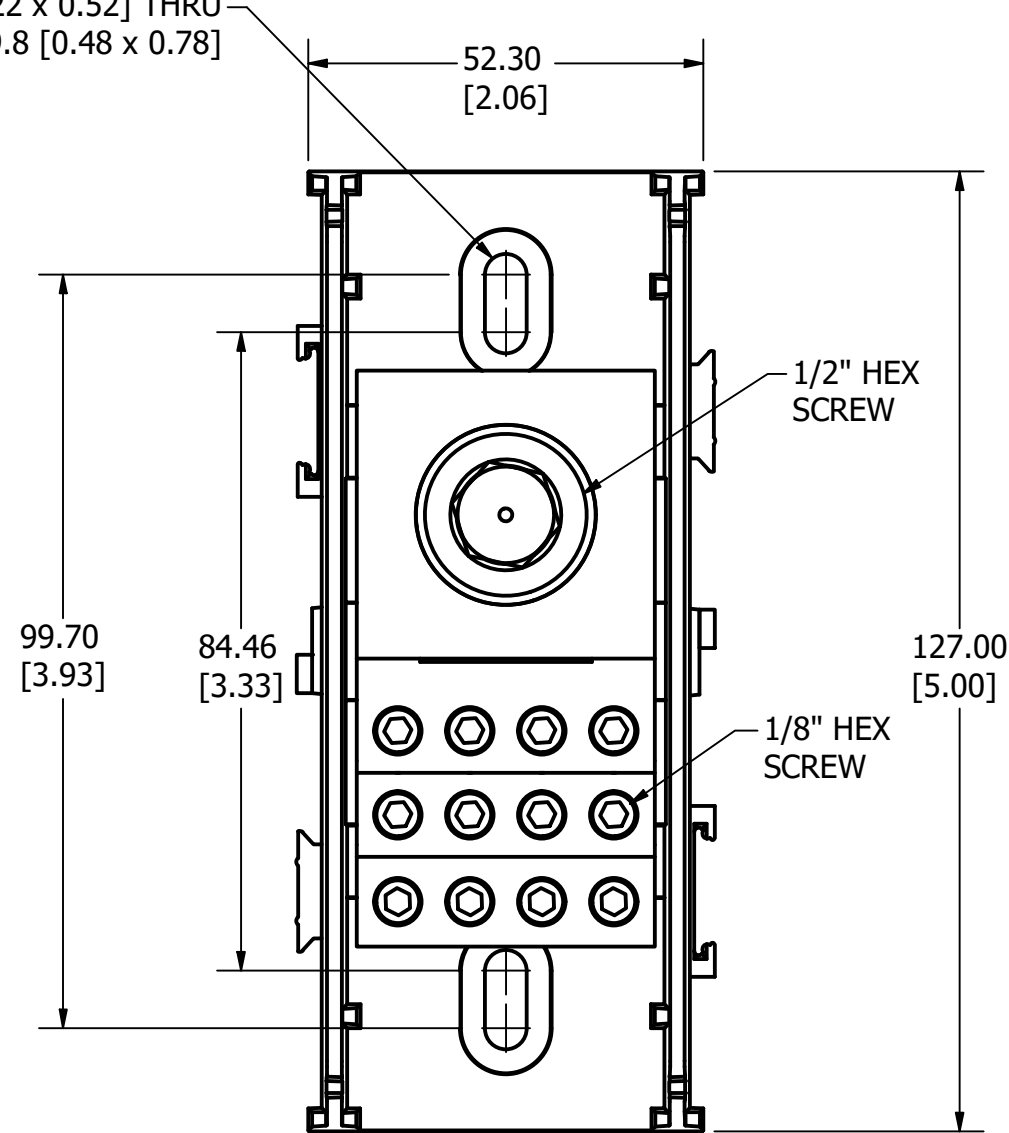

NOTES:

- AGENCY INFORMATION: cULus - UL LISTED TO UL 1953
EVALUATED TO CSA 22.2
- MATERIALS: INSULATOR BASE: HIGH IMPACT THERMOPLASTIC
FLAMMABILITY RATING UL94V0
TEMP RATING: -40°C TO 125°C (UL RTI)
CONNECTOR: ALUMINUM, TIN PLATED
TERMINAL SCREWS: 1/2": ALUMINUM, TIN PLATED
1/8": STEEL, NICKEL PLATED
CONNECTOR MOUNTING SCREWS: STEEL, ZINC PLATED
- TERMINATION: LINE: ALUMINUM, 600 kcmil - #2
LOAD: SOLID COPPER, #10 - 14 AWG
ALUMINUM, #4 - 6 AWG
- MAXIMUM AMP RATING PER POLE: 420A
BASED ON NEC WIRE RATING CODE, 75°C WIRE
- TORQUE: LINE: 42.4 N-m (375 lbf-in)
LOAD: 4.0 N-m (35 lbf-in)
- MOUNTING: USE #10 FASTENER. TORQUE NOT TO EXCEED
3.4 N-m (30 lbf-in).

TOLERANCE (UNLESS OTHERWISE SPECIFIED):

- 1 PLACE ± 2.5mm [0.10]
- 2 PLACE ± 0.76mm [0.03]
- 3 PLACE ± 0.381mm [0.015]

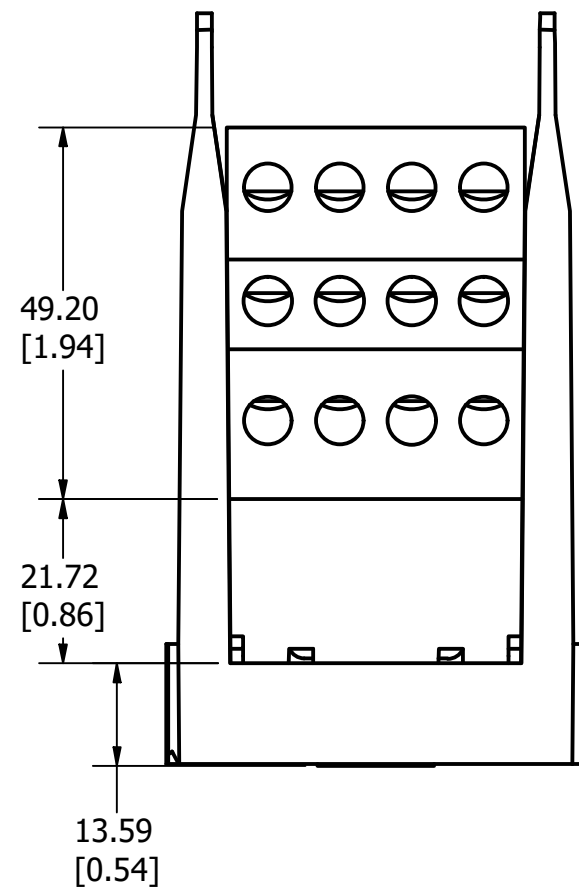

Littelfuse
POWER DISTRIBUTION BLOCK
CAT NO **OLD45951ZX**
LINE TORQUE
600 - 2 cual 375 lbf. in.

LOAD TORQUE
4 - 8 cual 35 lbf.in.
14cu 35 lbf.in.

600V 420A CU7AL
0 794581 31182 2
Made in USA

CLASS	LINE	LOAD	Over-Current Protection Fuse Required Class / Max Amp Rating						SCCR RMS Sym. Amps 600V Max
			J	T	RK1	RK5	G	CC	
B-C	600 - 3/0	4 - 6	450	450	400	200	80	30	100,000
	600 - 2	4 - 10	250	250	200	100	30	30	100,000
G, H, I	600 - 2	4 - 14	125	125	100	30	80	30	100,000
	350 - 3/0	6 - 8	450	450	400	200	80	30	100,000
	350 - 2	6 - 14	125	125	100	30	80	30	100,000
	600 - 2	2 - 14	None						

NO	COMPONENT NO	DESCRIPTION	QTY/M	U/M
BILL OF MATERIAL				
<S>		CRITICAL CHARACTERISTIC FOR PART SAFETY/COMPLIANCE		
●		DENOTES CRITICAL CHARACTERISTICS.		
CPK		DENOTES CPK DIMENSIONS, -MINIMUM CPK VALUE		
(ST)		DENOTES A CHARACTERISTIC THAT PROVIDES AN INDICATION OF PROCESS PERFORMANCE. PROCEDURE FOR MEASUREMENT AND TRACKING TO BE DEFINED IN LITTELFUSE INSPECTION INSTRUCTIONS.		
CP		DENOTES CP DIMENSIONS, -MINIMUM CP VALUE MUST BE WITHIN THE DIMENSIONAL LIMITATIONS SHOWN ON DRAWING AND INITIALLY LOCATED TO ALLOW FOR MAXIMUM TOOL LIFE.		C
MATL SPEC		FINISH		
DRW myork	DATE 1/25/2023	SCALE NTS	FINISH GOOD WT GRAMS/PIECE	
UNLESS OTHERWISE SPECIFIED, DIMENSIONS ARE IN MILLIMETERS, DIMENSIONS IN BRACKETS [] ARE INCHES DIMENSIONING AND DO NOT INCLUDE PLATING. TOLERANCING TO BE INTERPRETED IN ACCORDANCE WITH ANSI Y14.5M-1994				
3RD ANGLE PROJECTION				
TITLE DISTRIBUTION BLOCK 600V, 420A, 1 POLE OUTLINE				
Littelfuse CHICAGO, ILLINOIS 60631		REVISION A	DRWG NO. OL-LD45951	SHEET 1 OF 1