

PART NUMBER

OLD45851ZX

REVISION

REV	DATE	DESCRIPTION
A	3/11/24	527585GCP - RELEASE PER EM3406 MRY

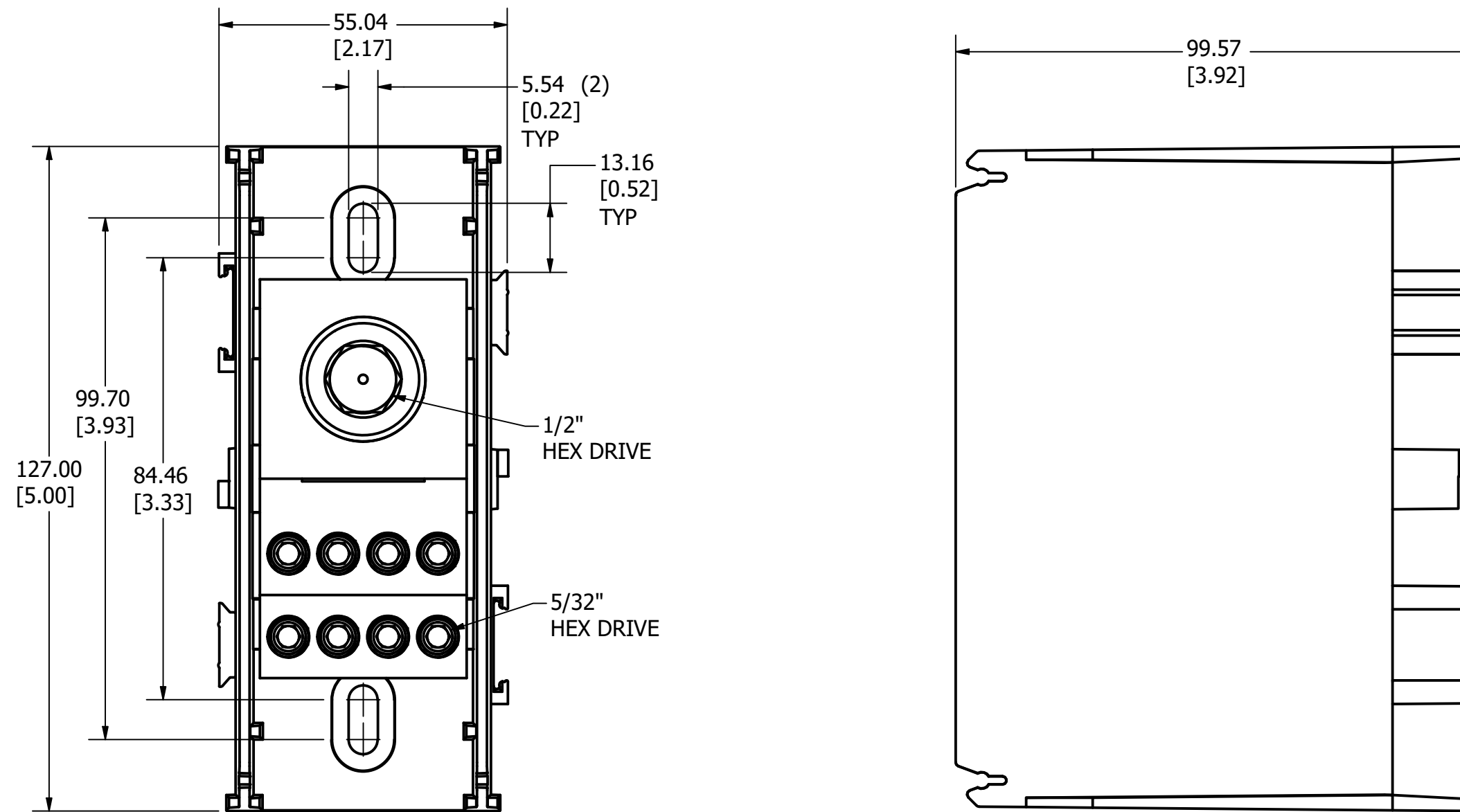

NOTES:

- AGENCY INFORMATION: cULus - UL LISTED TO UL 1953
EVALUATED TO CSA 22.2
- MATERIALS: INSULATOR BASE: HIGH IMPACT THERMOPLASTIC
FLAMMABILITY RATING UL94V0
TEMP RATING: -40°C TO 125°C (UL RTI)
CONNECTOR: ALUMINUM, TIN PLATED
LINE TERMINAL SCREWS: ALUMINUM, TIN PLATED
LOAD TERMINAL SCREWS: STEEL, NICKEL PLATED
CONNECTOR MOUNTING SCREWS: STEEL, ZINC PLATED
- TERMINATION: LINE: ALUMINUM, 600 kcmil - #2
LOAD: COPPER STRANDED, #2 - 14 AWG
SOLID COPPER, #10 - 14 AWG
ALUMINUM STRANDED, #2 - 6 AWG
- MAXIMUM AMP RATING PER POLE: 420A
BASED ON NEC WIRE RATING CODE, 75°C WIRE
- TORQUE: LINE: 42.4 N-m (375 lbf-in)
LOAD: #2 AWG: 5.6 N-m (50 lbf-in)
#4 - 6 AWG: 5.1 N-m (45 lbf-in)
#8 AWG: 4.5 N-m (40 lbf-in)
#10 - 14 AWG: 4 N-m (35 lbf-in)

- MOUNTING: USE #10 FASTENER. TORQUE NOT TO EXCEED
3.4 N-m (30 lbf-in).

TOLERANCE (UNLESS OTHERWISE SPECIFIED):

- PLACE ± 2.5mm [0.10]
- PLACE ± 0.76mm [0.03]
- PLACE ± 0.381mm [0.015]

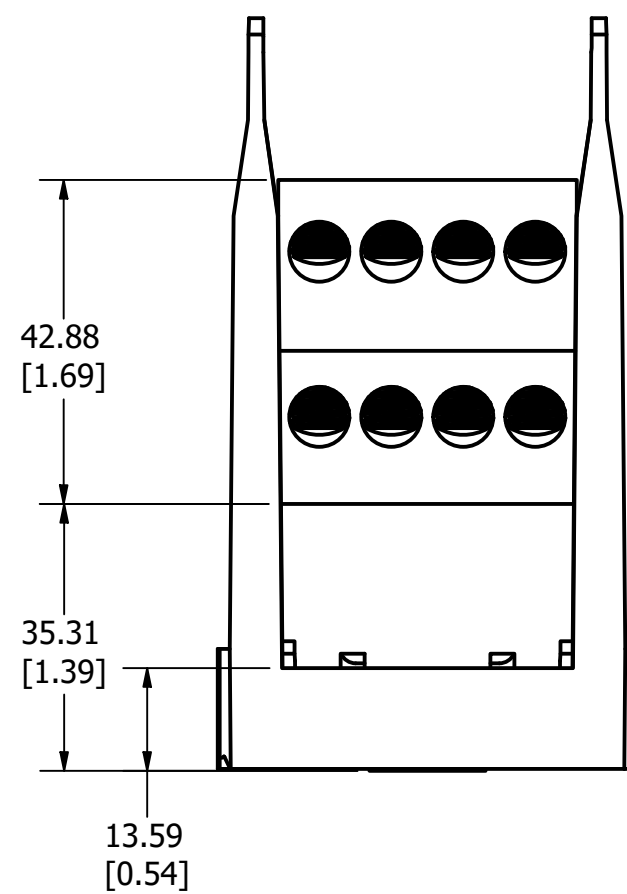

Littelfuse
POWER DISTRIBUTION BLOCK
CAT NO **OLD45851ZX**
LINE TORQUE
600 - 2 cual 375 lbf. in.
LOAD TORQUE
2 cual 50 lbf.in.
4 - 6 cu 45 lbf.in.
8 cual 40 lbf.in.
10 - 14 cu 35 lbf.in.
600V 420A CU7AL
0 79458 31178 5
Made in USA

CLASS	LINE	LOAD	Over-Current Protection Fuse Required						SCCR RMS Sym. Amps 600V Max
			J	T	RK1	RK5	G	CC	
B-C	600 - 3/0	2 - 6	450	450	400	200	60	30	100,000
	600 - 2	2 - 10	250	250	200	100	60	30	100,000
G, H, I	600 - 2	2 - 14	125	125	100	30	60	30	100,000
	350 - 3/0	4 - 6	450	450	400	200	60	30	100,000
	350 - 2	4 - 14	125	125	100	30	60	30	100,000
	600 - 2	2 - 14	None						10,000

NO	COMPONENT NO	DESCRIPTION	QTY/M	U/M
BILL OF MATERIAL				
<S>		CRITICAL CHARACTERISTIC FOR PART SAFETY/COMPLIANCE		
●		DENOTES CRITICAL CHARACTERISTICS.		
CPK		DENOTES CPK DIMENSIONS, -MINIMUM CPK VALUE		
(ST)		DENOTES A CHARACTERISTIC THAT PROVIDES AN INDICATION OF PROCESS PERFORMANCE. PROCEDURE FOR MEASUREMENT AND TRACKING TO BE DEFINED IN LITTELFUSE INSPECTION INSTRUCTIONS.		
CP		DENOTES CP DIMENSIONS, -MINIMUM CP VALUE MUST BE WITHIN THE DIMENSIONAL LIMITATIONS SHOWN ON DRAWING AND INITIALLY LOCATED TO ALLOW FOR MAXIMUM TOOL LIFE.		C
MATL SPEC		FINISH		
DRW myork	DATE 1/25/2023	SCALE NTS	FINISH GOOD WT GRAMS/PIECE	
UNLESS OTHERWISE SPECIFIED, DIMENSIONS ARE IN MILLIMETERS, DIMENSIONS IN BRACKETS [] ARE INCHES DIMENSIONING AND DO NOT INCLUDE PLATING. TOLERANCING TO BE INTERPRETED IN ACCORDANCE WITH ANSI Y14.5M-1994				
3RD ANGLE PROJECTION				
TITLE DISTRIBUTION BLOCK 600V, 420A, 1 POLE OUTLINE				
Littelfuse CHICAGO, ILLINOIS 60631		REVISION A	DRWG NO. OL-LD45851	SHEET 1 OF 1