

PART NUMBER	"A"	"B"	"C"	"D"	LEAD "A" COLOR	LEAD "B" COLOR
FHAC0003ZXJA	89.3±5 (3.516)	89.3±5 (3.516)	6.35±2 (0.25)	6.35±2 (0.25)	RED	RED
FHAC0003ZXJB	89.3±5 (3.516)	89.3±5 (3.516)	6.35±2 (0.25)	6.35±2 (0.25)	RED WITH BLUE STRIPE	RED WITH BLUE STRIPE

LTR	DATE	REVISION	CHK	APD
A	11/21/07	00021BER-RELEASE FHAC0003ZXJA AND FHAC0003ZXJB DHM		
B	04/30/15	511837ECA-REMOVE MODEL NAME OF HOLDER MATERIAL		

- NOTES:
- HOLDER MATERIAL: BLACK TPV
  - CONTACTS: COPPER ALLOY TIN-PLATED
  - WIRE: 14 AWG STRANDED COPPER, 125°C RATED, GXL WIRE
  - CRIMP: MUST MEET SAE/JUSCAR 21 STANDARD
  - RATING: MAX. 25A, 32Vdc
  - MAX TEMPERATURE 105°C
  - DATE CODE AND MOLD CAVITY NUMBER MARKED ON ALL UNITS.

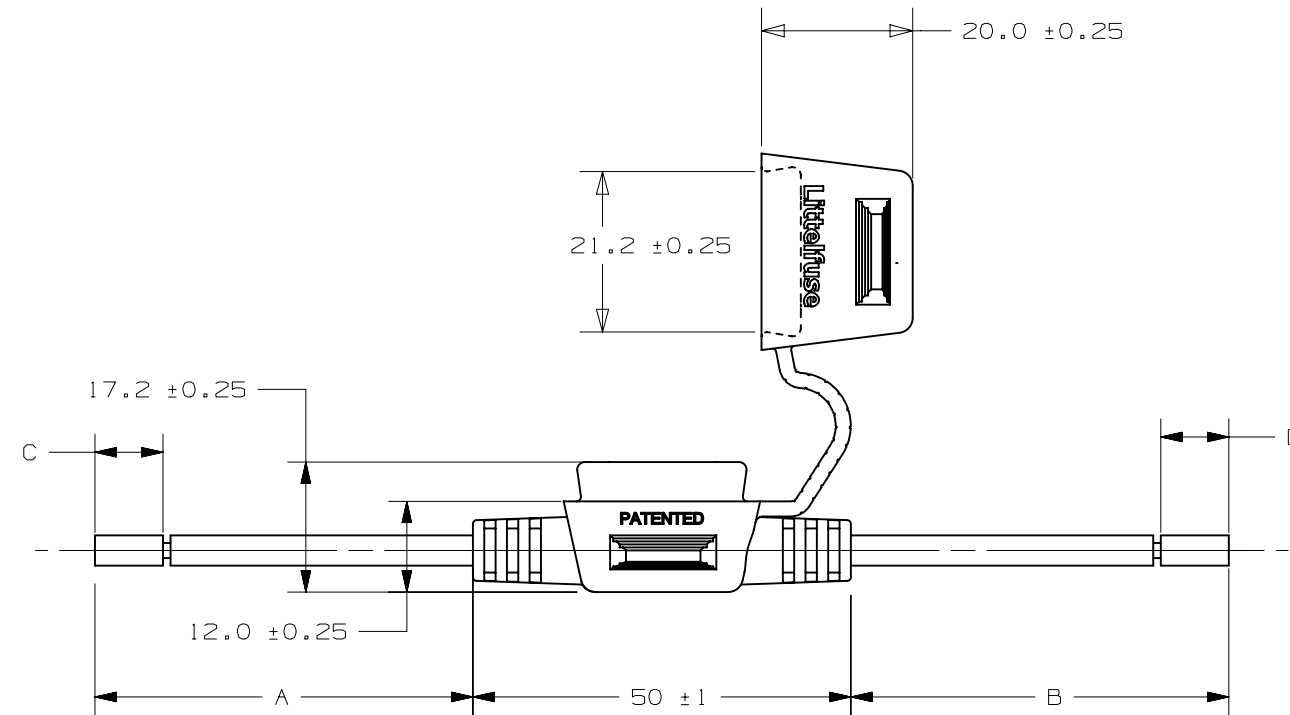
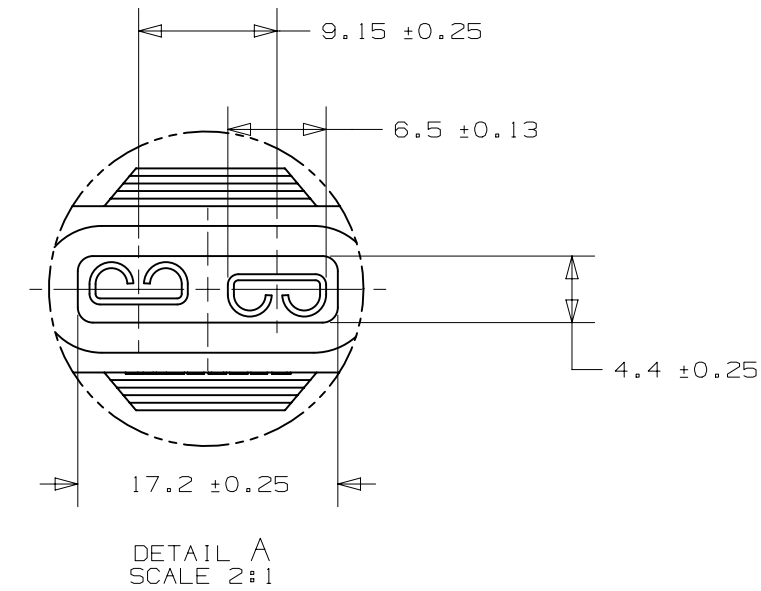
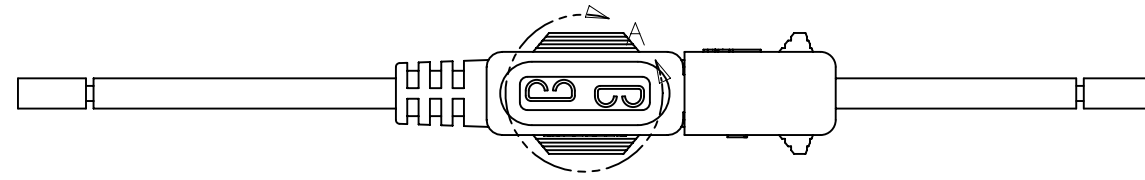

UNLESS OTHERWISE SPECIFIED, DIMENSIONS ARE IN MILLIMETERS. DIMENSIONS IN BRACKETS [ ] ARE INCHES			
UNLESS OTHERWISE SPECIFIED, DIMENSIONS DO NOT INCLUDE PLATING.			
⊙	DENOTES CRITICAL CHARACTERISTICS.		
CPK	DENOTES CPK DIMENSIONS, -MINIMUM CPK VALUE		
⊙ST	DENOTES A CHARACTERISTIC THAT PROVIDES AN INDICATION OF PROCESS PERFORMANCE. PROCEDURE FOR MEASUREMENT AND TRACKING TO BE DEFINED IN LITTELFUSE INSPECTION INSTRUCTIONS		
CP	DENOTES CP DIMENSIONS, -MINIMUM CP VALUE MUST BE WITHIN THE DIMENSIONAL LIMITATIONS SHOWN ON DRAWING AND INITIALLY LOCATED TO ALLOW FOR MAXIMUM TOOL LIFE		
COPIES TO	MATL SPEC SEE NOTES		
1 9 18	FINISH SEE NOTES		
2 10 19	DRW	DATE	SCALE
3 12 20	DHM	11/21/07	1:1
4 13 21	CHK	DATE	SUPER DR
5 14 23	APPD	DATE	FINSH GOOD WT
6 15 33			GRAMS/PIECE
7 16 43			
8 17 53			
TOLERANCE UNLESS OTHERWISE SPECIFIED			
ONE PLACE DEC +/- .3		THREE PLACE DEC +/- .100	
TWO PLACE DEC +/- .25		ANGULAR +/- 1°	
3RD ANGLE PROJECTION	TITLE	ATO IN-LINE FUSEHOLDER	
	REVISION	DRWG. NO. OUTLINE SERIES	
	B	FHAC0003ZXJ	

METRIC

CAD GENERATED DRAWING - NO PENCIL CHANGES ALLOWED