

THIS DRAWING AND THE INFORMATION CONTAINED WITHIN IT ARE CONFIDENTIAL AND MAY NOT BE COPIED OR DISCLOSED WITHOUT THE WRITTEN PERMISSION OF LITTELFUSE.

PART NO.	COLOR
81277	RED
81277-1	YELLOW
81277-2	BLACK

REVISIONS				
ZONE	REV.	DESCRIPTION	DATE	APPROVED
	A	PCO #5300102. INITIAL RELEASE. DSILVA.	10/13/2022	L.ARGIL

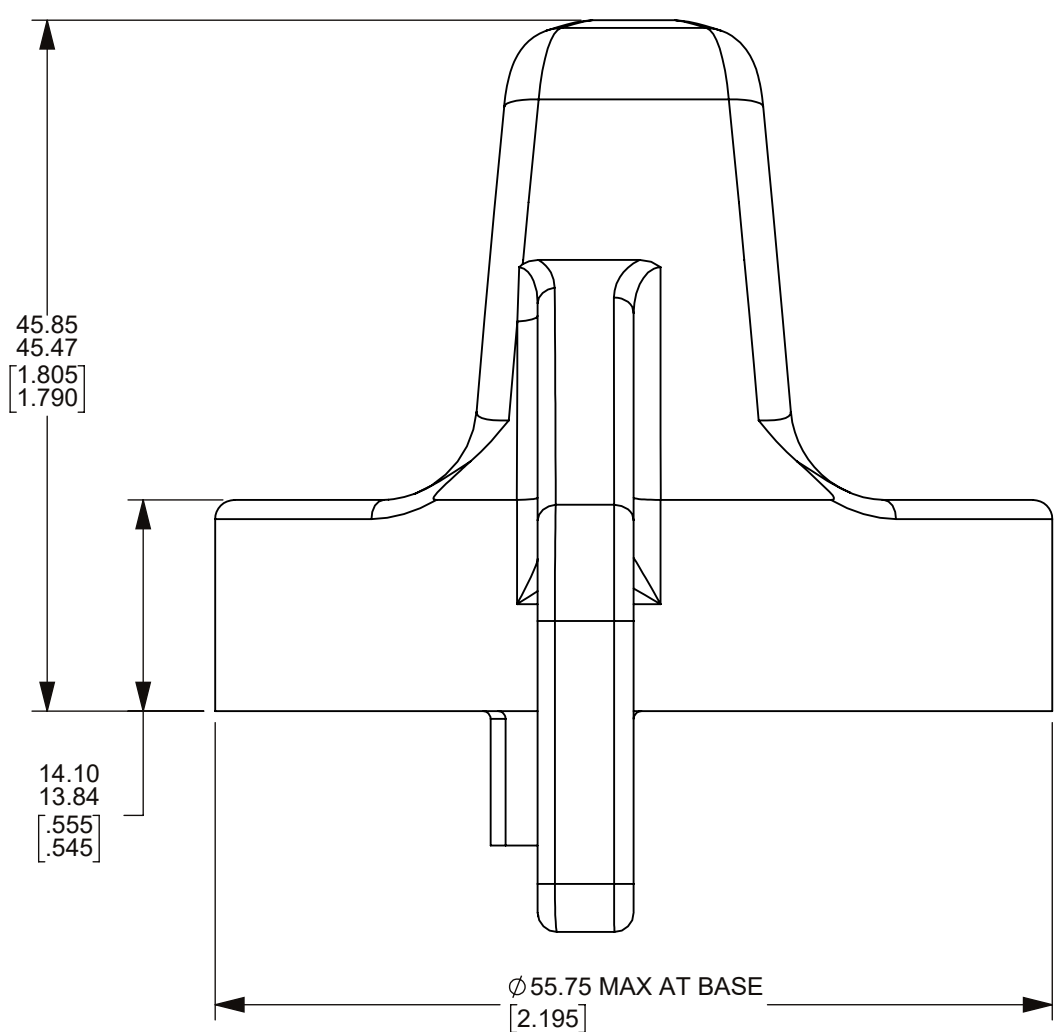
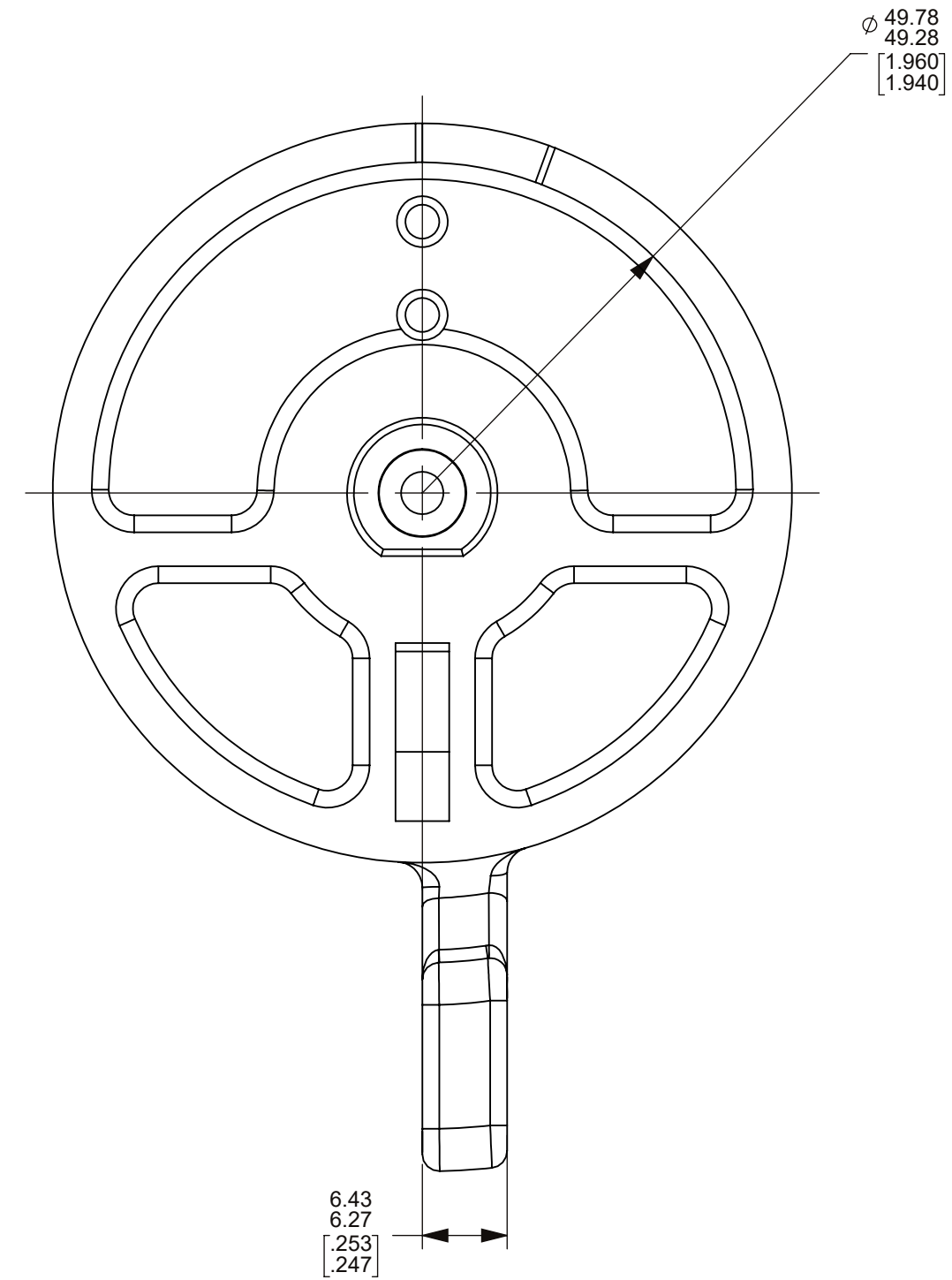
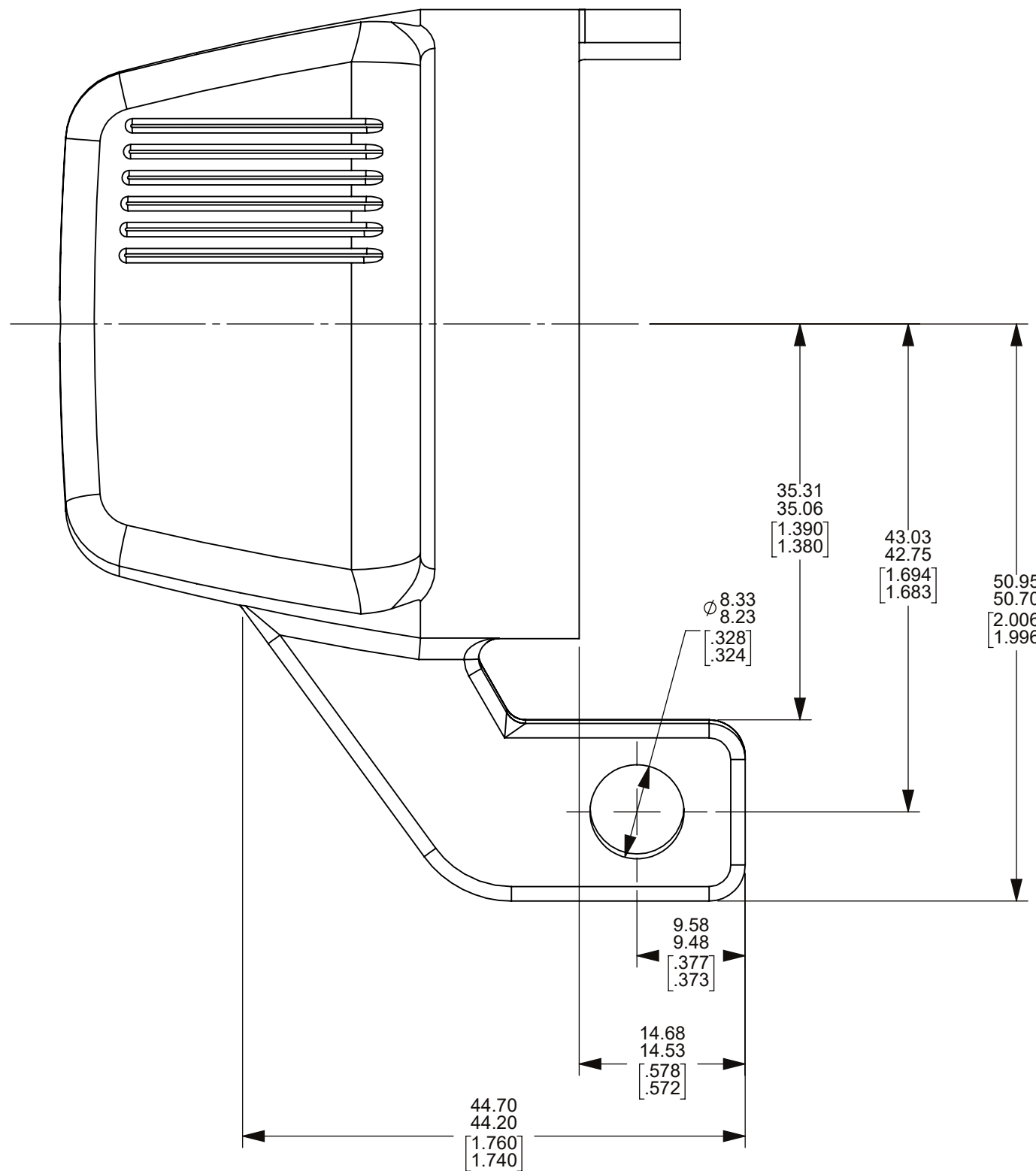
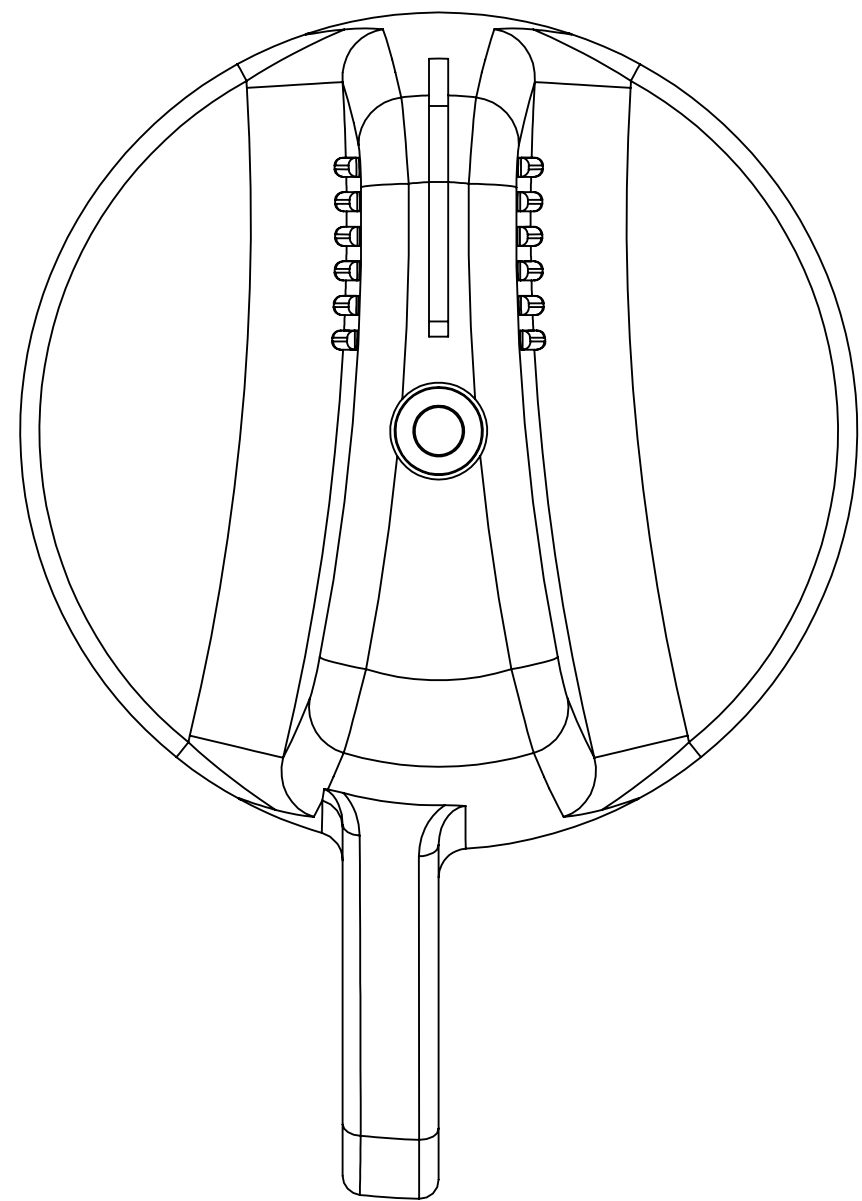

- NOTES:
1. MATERIAL: PBT/PC, COLOR SEE CHART.
  2. DIMENSIONS IN INCHES ARE SHOWN IN [ ] (REFERS TO EQUIVALENT METRIC DIMENSION TOLERANCE).
  3. ALL TOLERANCES ARE NON-CUMULATIVE.
  4. DIMENSIONS IN INCHES ARE MANDATORY.

NO.	COMPONENT NO.	COMPONENT NAME	QTY	U
TOLERANCES UNLESS OTHERWISE SPECIFICALLY NOTED, THE FOLLOWING ARE THE DEFAULT TOLERANCES (INCHES).				
TWO PLACES ±0.02"		THREE PLACES ±0.005"	ANGULAR ±1°	
DIMENSIONS ARE SHOWN IN MILLIMETERS. DIMENSIONS AND TOLERANCES ARE DEFINED ACCORDING TO ANSI/ASME Y14.5-1994.				
●	FIT/ FUNCTION CRITICAL CHARACTERISTICS			
<S>	SAFETY/ COMPLIANCE CRITICAL CHARACTERISTICS SYMBOL			
CPK	DENOTES CPK DIMENSIONS MINIMUM CPK VALUE			
(ST)	DENOTES A CHARACTERISTIC THAT PROVIDES AN INDICATION OF PROCESS PERFORMANCE. PROCEDURE FOR MEASUREMENT AND TRACKING TO BE DEFINED IN LITTELFUSE INSPECTION INSTRUCTIONS			
CP	DENOTES CP DIMENSIONS. -MINIMUM CP VALUE MUST BE WITHIN THE DIMENSIONAL LIMITATIONS SHOWN ON DRAWING AND INITIALLY LOCATED TO ALLOW FOR MAXIMUM TOOL LIFE			
NAME	DATE	Littelfuse		
DRAWN DSILVA	7/27/2022	Expertise Applied   Answers Delivered		
CHECKED		TITLE		
		KNOB		
FORM NO. CVP-PE40-0005 REV B		SIZE C	DWG. NO. OL-81277	REV. A
THIRD ANGLE PROJECTION		OUTLINE		
DO NOT SCALE DRAWING		SCALE 2:1	SHEET 1 OF 1	