

REV.		DESCRIPTION	DATE	GCF / ECR	DESIGNED	APPROVED
A		Initial Release	1-Feb-23		L.Dal Molin	M.Tinto

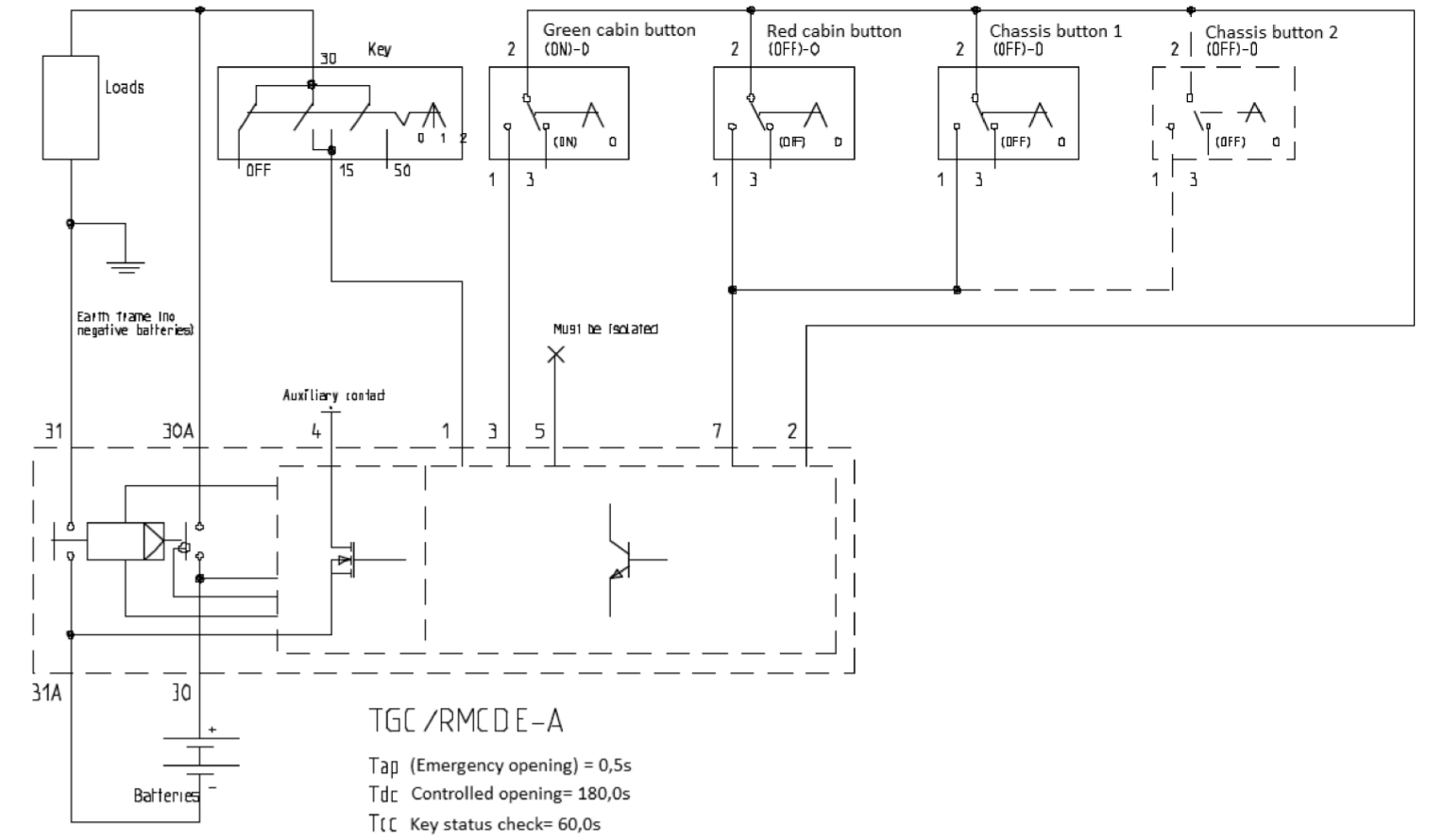
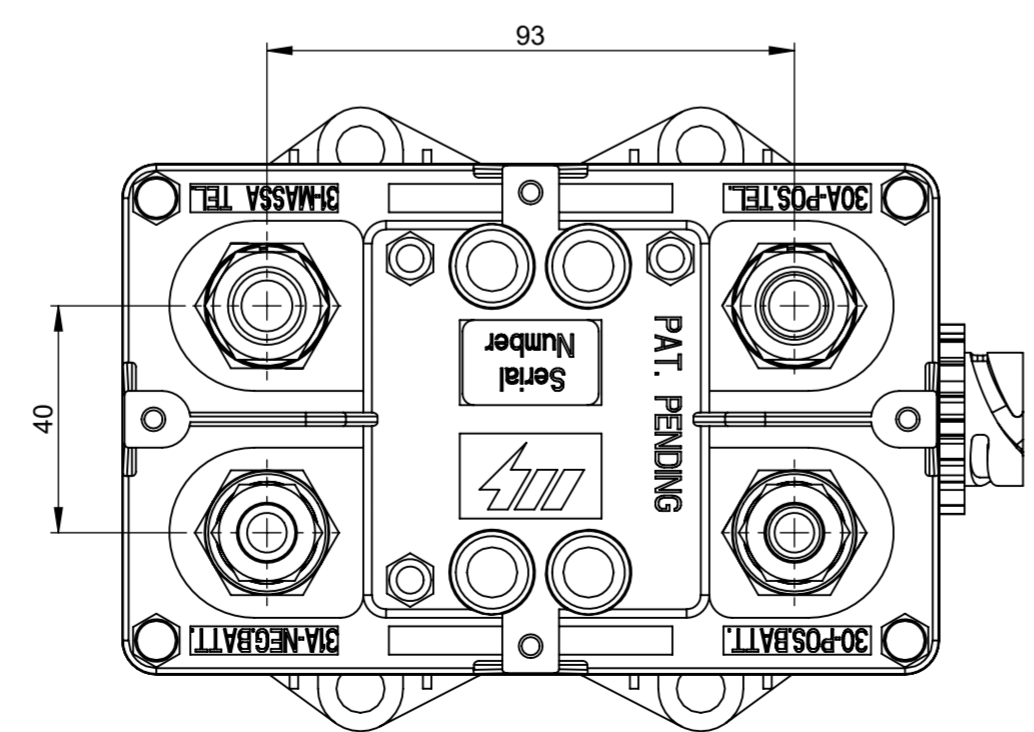
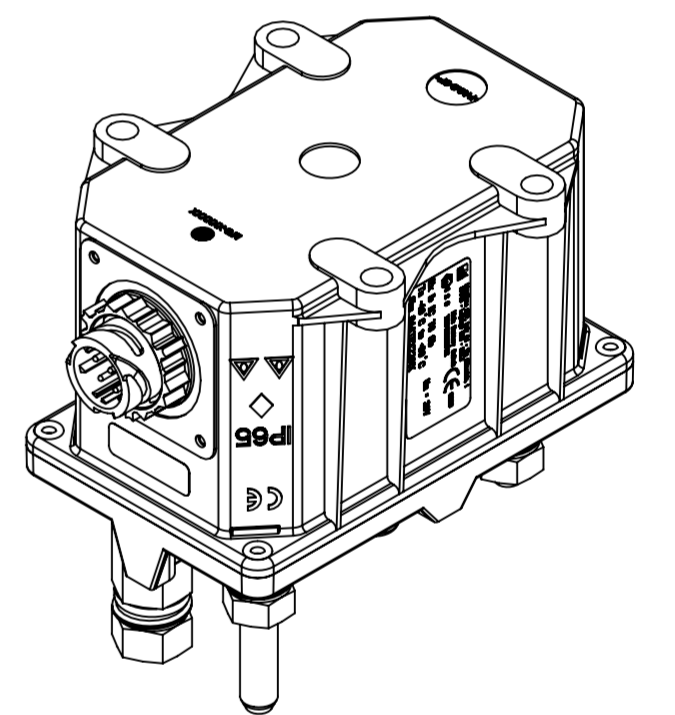
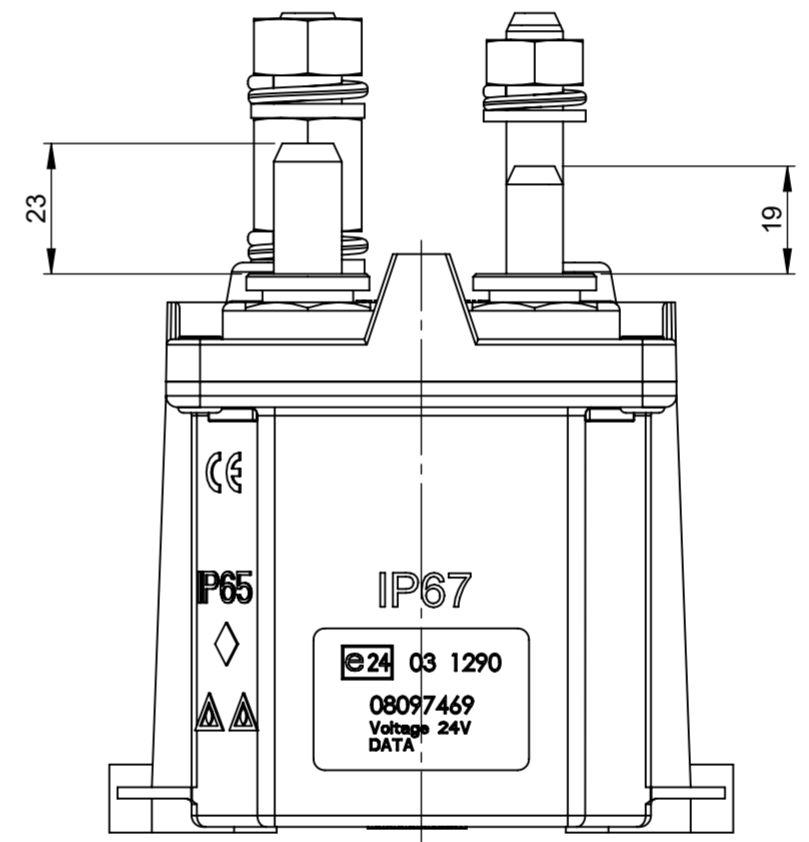
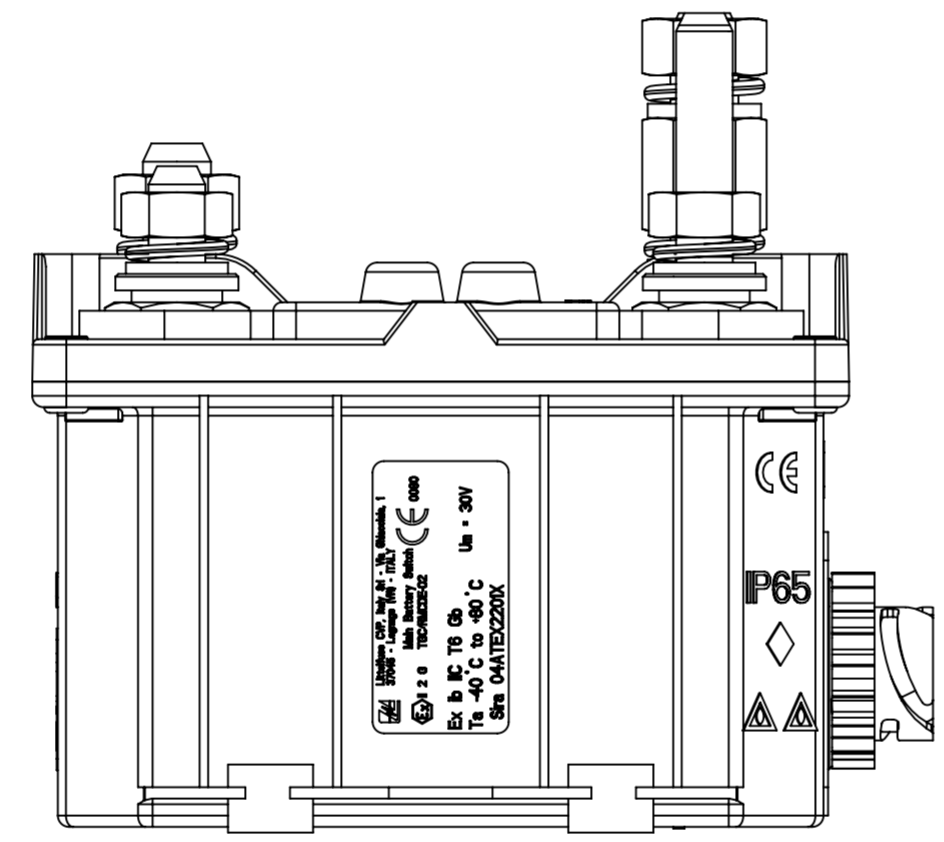
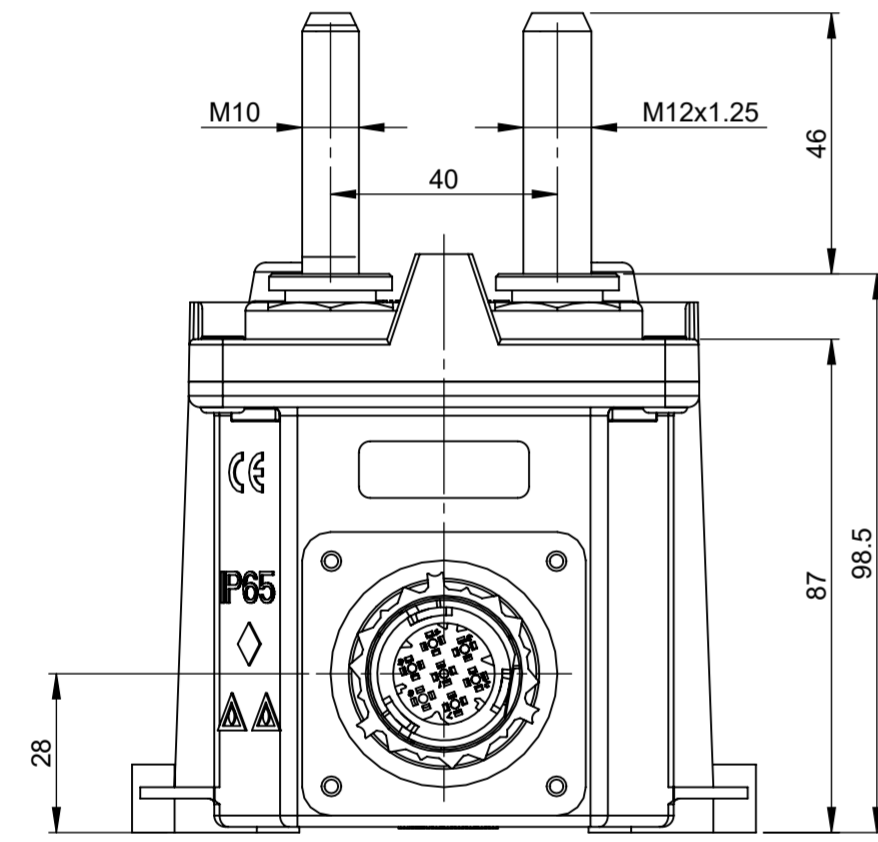
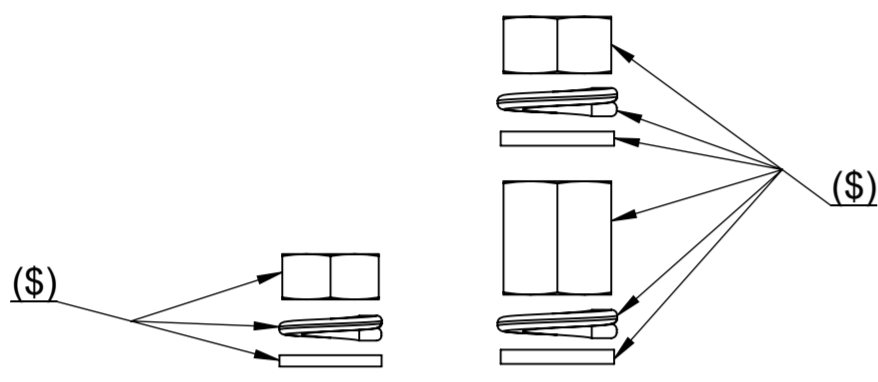
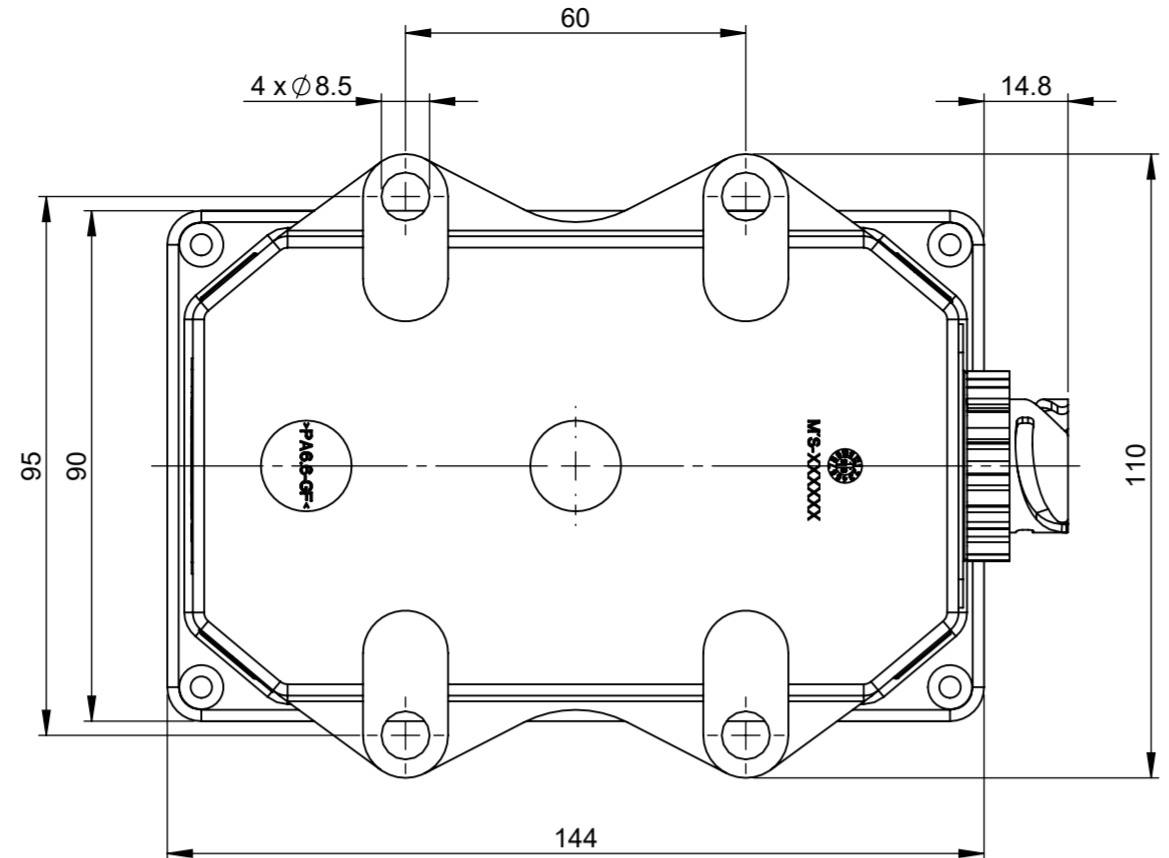

DOCUMENTO CORRELATO AL CERTIFICATO:
 DOCUMENT CORRELATED TO THE CERTIFICATE:

SIRA 04 ATEX 2201X

Non sono ammesse modifiche senza l'approvazione della "Persona Autorizzata".
 No modify is allowed without the "Authorized Person" approval.

CHARACTERISTICS

- Nominal operating voltage: 24V
- Working voltage: 27V
- Working voltage range: 12 ÷ 36V
- Max continuous current on contacts: 250A
- Max current short duration on contacts: 2000A for 30 sec. 2500A for 5 sec.
- Number of mechanical and electrical cycles: 100.000
- Max torque of screws M10/M12= 22 ± 1 Nm
- We suggest to fix the Bms to the structure by screws M8 and plane washers under head with torque 10 ± 2 Nm
- (\$) Components provided in the kit

DIMENSIONS AND TOLERANCES IN MILLIMETERS, DEFINED ACCORDING TO ISO 1101-2017.

linear dimensions						
0,5	>3	>6	>30	>120	>400	>1000
3	6	30	120	400	1000	2000
±0,2	±0,3	±0,5	±0,8	±1,2	±2	±3

angle (for range of lengths)			
up to 10	>10	>50	>120
10	50	120	400
±1°30'	±1°	±0°30'	±0°15'

●	FIT/ FUNCTION CRITICAL CHARACTERISTICS SYMBOL	
<S>	SAFETY/ COMPLIANCE CRITICAL CHARACTERISTICS SYMBOL	
CPK	DENOTES CPK DIMENSIONS MINIMUM CPK VALUE	
ST	DENOTES A CHARACTERISTIC THAT PROVIDES AN INDICATION OF PROCESS PERFORMANCE. PROCEDURE FOR MEASUREMENT AND TRACKING TO BE DEFINED IN LITTELFUSE INSPECTION INSTRUCTIONS	
CP	DENOTES CP DIMENSIONS. MINIMUM CP VALUE MUST BE WITHIN THE DIMENSIONAL LIMITATIONS SHOWN ON DRAWING AND INITIALLY LOCATED TO ALLOW FOR MAXIMUM TOOL LIFE	
DRAWN		DATE
L. Dal Molin		1 Feb 2023
CHECKED		
FORM NO: CVP-PE40-0013 REV A		TITLE
FIRST ANGLE PROJECTION		BMS TGC/RMCDE-O2 24V
SIZE: A2	DWG. NO. OL-08097469	OUTLINE REV. A
DO NOT SCALE DRAWING	SCALE 1:1	SHEET 1 OF 1

