

THIS DRAWING AND THE INFORMATION CONTAINED WITHIN IT ARE CONFIDENTIAL AND MAY NOT BE COPIED OR DISCLOSED WITHOUT THE WRITTEN PERMISSION OF LITTELFUSE.

REVISIONS					
REV.	DESCRIPTION	DATE	GCF / ECR	DESIGNED	APPROVED
A	Initial release	21-Jun-22		L.Dal Molin	M.Tinto

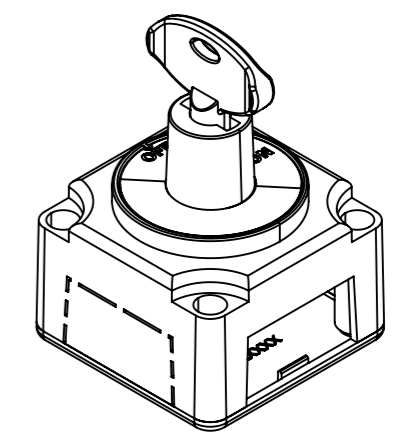

SCALE 1:2

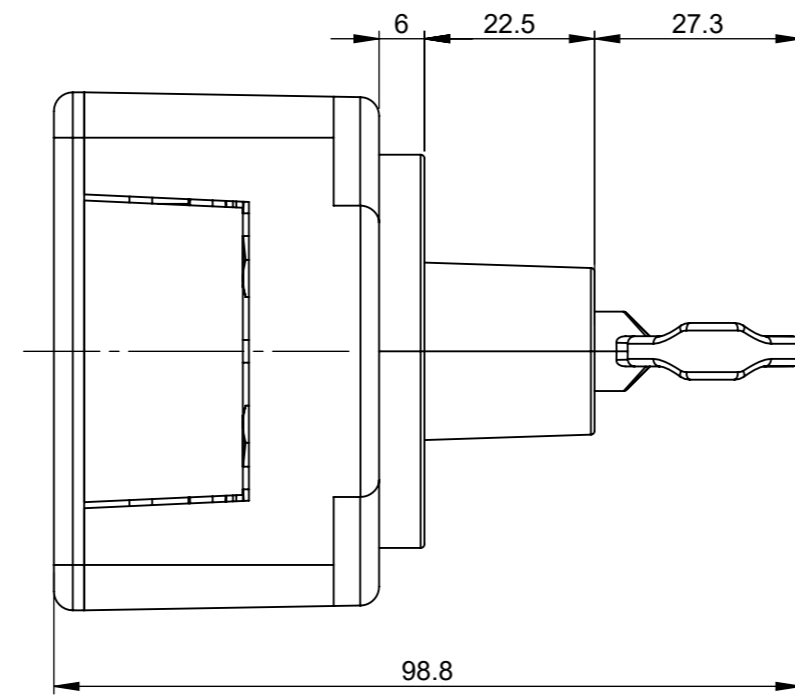
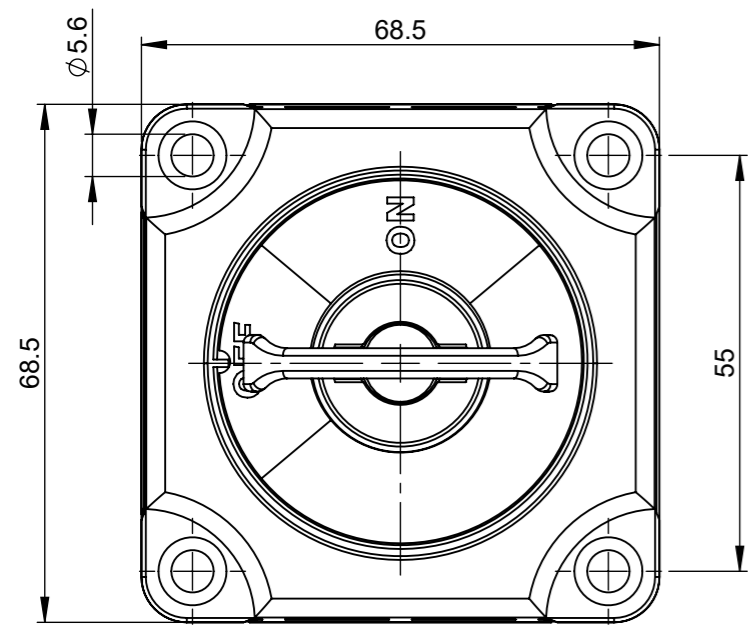
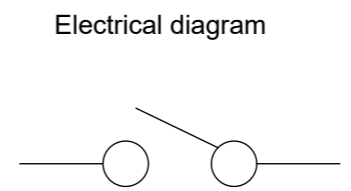
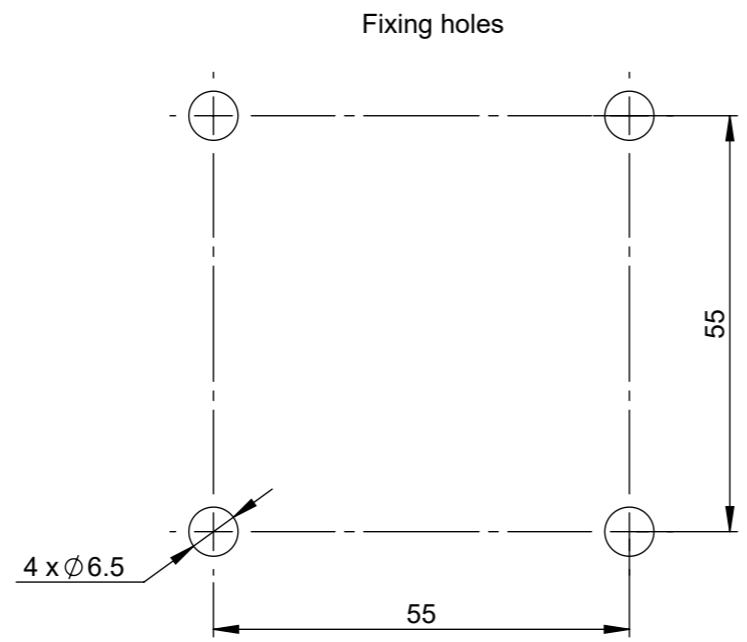
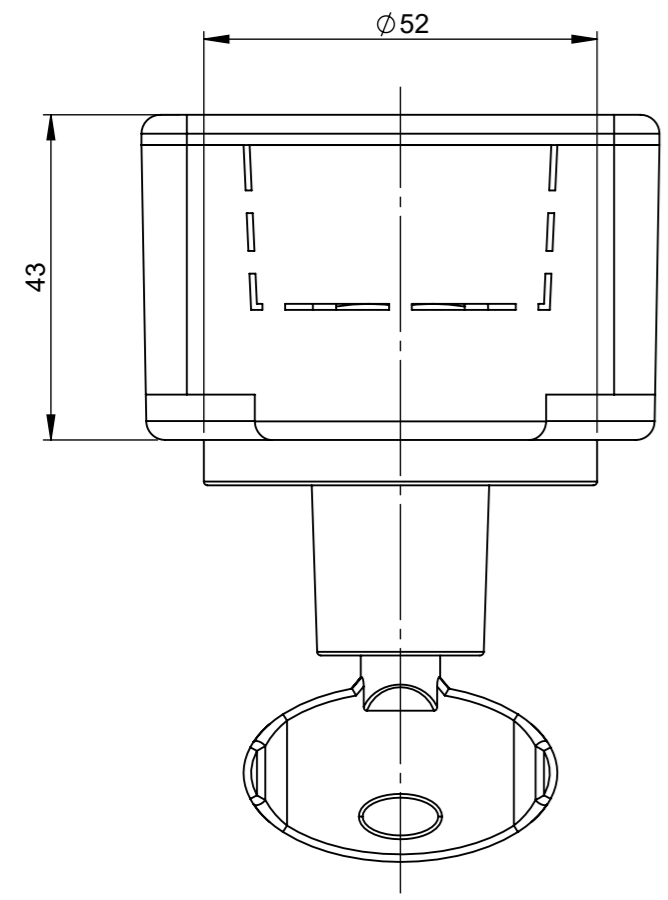

- CHARACTERISTICS AND PRESCRIPTIONS**
- Nominal tension: 24V
  - Max continuous operating current: 300A
  - Highest load 1000A for 5sec.
  - M10 nut torque:  $20 \pm 2$  Nm
  - M6 screw torque:  $8 \pm 1$  Nm

DIMENSIONS AND TOLERANCES IN MILLIMETERS, DEFINED ACCORDING TO ISO 1101-2017.

linear dimensions						
0,5	>3	>6	>30	>120	>400	>1000
3	6	30	120	400	1000	2000
$\pm 0,2$	$\pm 0,3$	$\pm 0,5$	$\pm 0,8$	$\pm 1,2$	$\pm 2$	$\pm 3$
angle (for range of lengths)						
up to 10	>10	>50	>120	>400		
$\pm 1^{\circ}30'$	$\pm 1^{\circ}$	$\pm 0^{\circ}30'$	$\pm 0^{\circ}15'$			

●	FIT/ FUNCTION CRITICAL CHARACTERISTICS SYMBOL
<S>	SAFETY/ COMPLIANCE CRITICAL CHARACTERISTICS SYMBOL
CPK	DENOTES CPK DIMENSIONS MINIMUM CPK VALUE
ST	DENOTES A CHARACTERISTIC THAT PROVIDES AN INDICATION OF PROCESS PERFORMANCE. PROCEDURE FOR MEASUREMENT AND TRACKING TO BE DEFINED IN LITTELFUSE INSPECTION INSTRUCTIONS
CP	DENOTES CP DIMENSIONS, -MINIMUM CP VALUE MUST BE WITHIN THE DIMENSIONAL LIMITATIONS SHOWN ON DRAWING AND INITIALLY LOCATED TO ALLOW FOR MAXIMUM TOOL LIFE

NAME	DATE	<p><b>Expertise Applied   Answers Delivered</b></p>
DRAWN	L. Bisognin 21-Jun-22	
CHECKED	-	
TITLE		<p>IGC-MARINE MANUAL 24V (ON/OFF)</p>
FORM NO: CVP-PE40-0013 REV A		
FIRST ANGLE PROJECTION		<p>SIZE: A3 DWG. NO. OL-08080800 OUTLINE REV. A</p>
DO NOT SCALE DRAWING		<p>SCALE 1:1 SHEET 1 OF 1</p>