

THIS DRAWING AND THE INFORMATION CONTAINED WITHIN IT ARE CONFIDENTIAL AND MAY NOT BE COPIED OR DISCLOSED WITHOUT THE WRITTEN PERMISSION OF LITTELFUSE.

REVISIONS					
REV.	DESCRIPTION	DATE	GCF / ECR	DESIGNED	APPROVED
A	Initial release	10-Jun-22		L.Dal Molin	M.Tinto

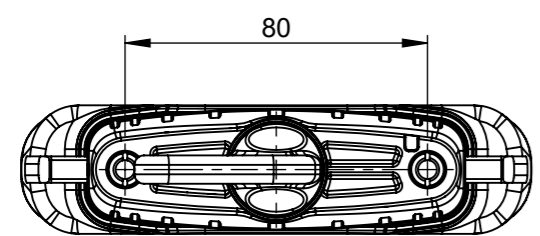
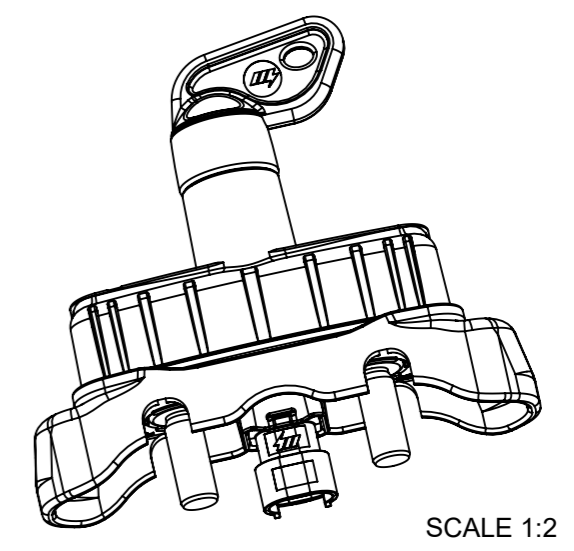
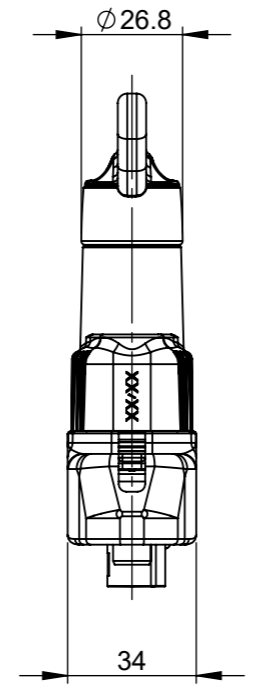
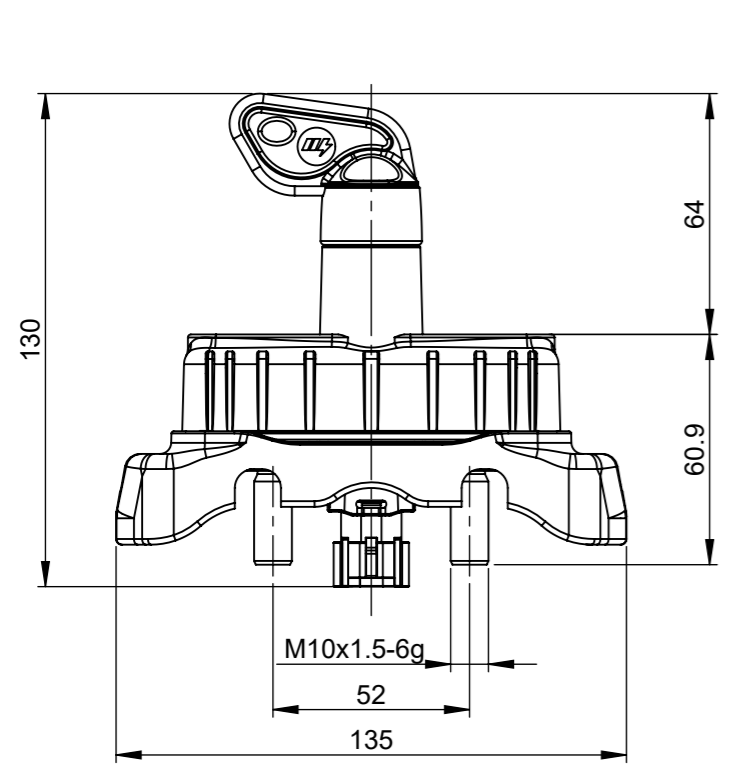

**CHARACTERISTICS**

- Rated tension: 28.5V
- Working tension range: from 8V to 34V
- Maximum continuous current in the main contact: 250A at 23°C
- Maximum current of short duration in the main contact: 1500A for 5sec at 23°C
- Number of mechanical and electrical cycles: 20.000
- Max key locking torque recommended: 7Nm
- Screws recommended to fix M6 with locking torque: 10 ± 1.5 Nm
- Screwing torque on main contacts M10: 18 ± 1 Nm

Electrical diagram

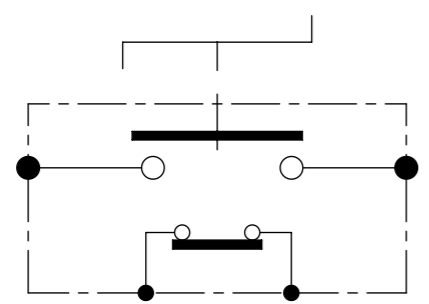

Fixing holes

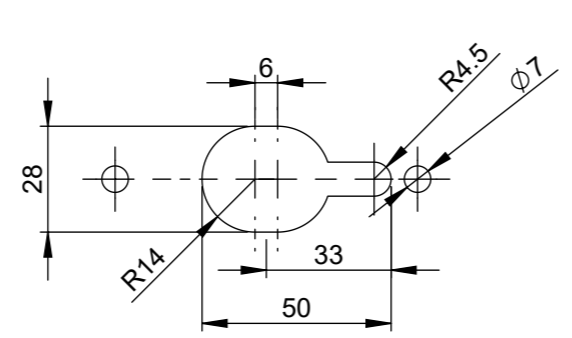

DIMENSIONS AND TOLERANCES IN MILLIMETERS, DEFINED ACCORDING TO ISO 1101-2017.

linear dimensions						
0,5	>3	>6	>30	>120	>400	>1000
3	6	30	120	400	1000	2000
±0,2	±0,3	±0,5	±0,8	±1,2	±2	±3

angle (for range of lengths)			
up to 10	>10	>50	>120
	50	120	400
±1°30'	±1°	±0°30'	±0°15'

●	FIT/ FUNCTION CRITICAL CHARACTERISTICS SYMBOL
<S>	SAFETY/ COMPLIANCE CRITICAL CHARACTERISTICS SYMBOL
CPK	DENOTES CPK DIMENSIONS MINIMUM CPK VALUE
ST	DENOTES A CHARACTERISTIC THAT PROVIDES AN INDICATION OF PROCESS PERFORMANCE. PROCEDURE FOR MEASUREMENT AND TRACKING TO BE DEFINED IN LITTELFUSE INSPECTION INSTRUCTIONS
CP	DENOTES CP DIMENSIONS, -MINIMUM CP VALUE MUST BE WITHIN THE DIMENSIONAL LIMITATIONS SHOWN ON DRAWING AND INITIALLY LOCATED TO ALLOW FOR MAXIMUM TOOL LIFE

NAME	DATE	<p><b>Expertise Applied   Answers Delivered</b></p>
DRAWN	L. Dal Molin 10-Jun-22	
CHECKED	-	
FORM NO: CVP-PE40-0013 REV A		TITLE
FIRST ANGLE PROJECTION		IGC/100-D-V
SIZE: A3	DWG. NO.	OUTLINE REV.
	OL-08080560	A
DO NOT SCALE DRAWING	SCALE 1:2	SHEET 1 OF 1