

LTR	DATE	REVISION	CHK	APD
A	06/05/14	RELEASE FOR PRODUCTION, PVN, EC#510590	PVN	
B	11/11/14	UPDATE DIMENSIONS AND TOLERANCE, JSN, EC#511259	JSN	

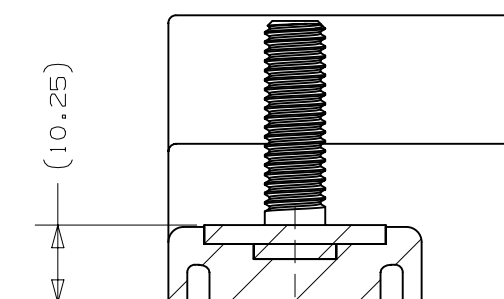
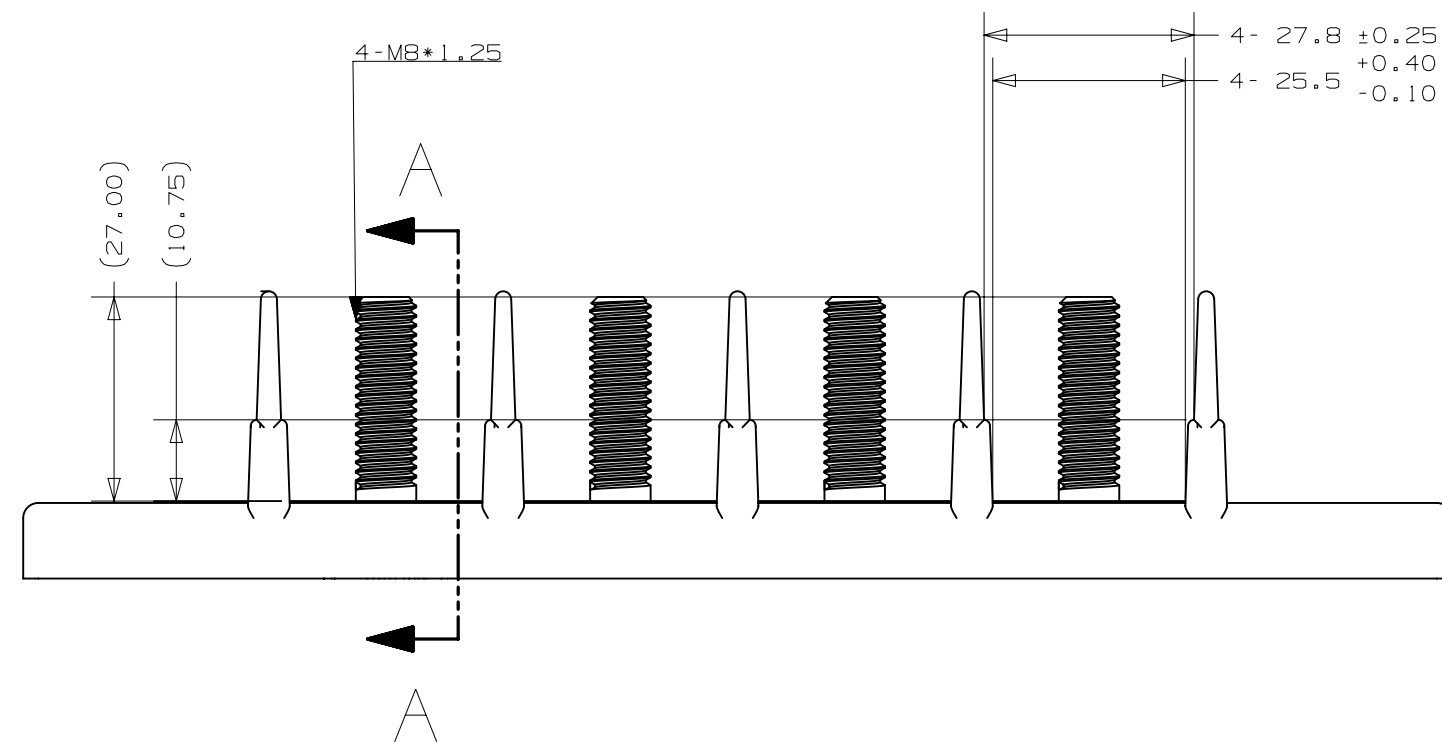
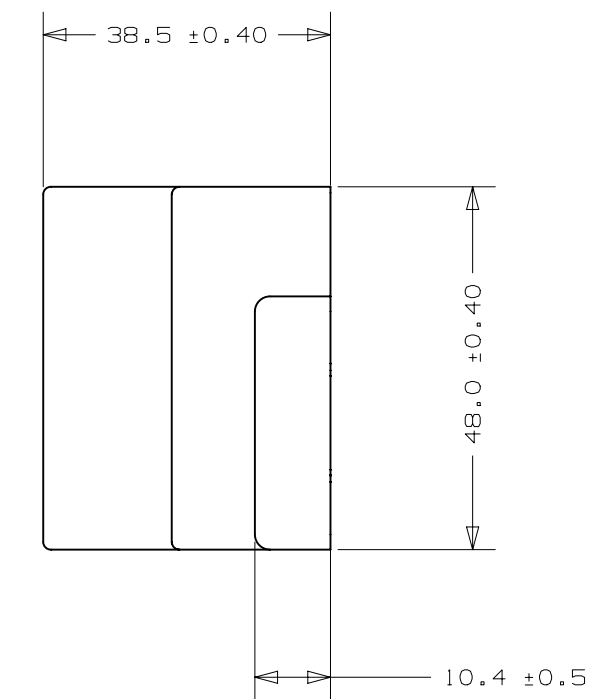
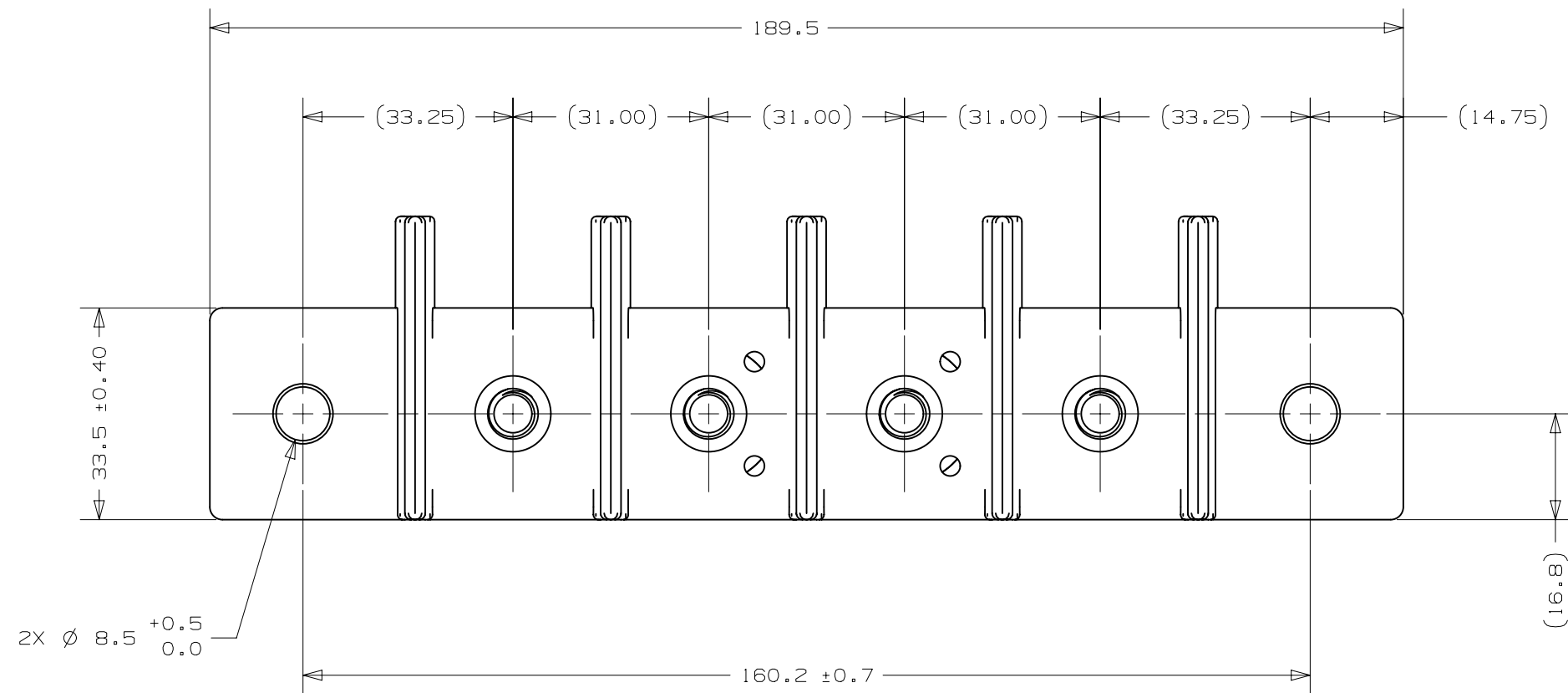

SECTION A-A

- NOTES:
- MATERIALS:
 BOLTS: ZINC PLATED STEEL
 BUS BAR: TIN PLATED COPPER
 BASE: PA6T/66-GF33 UL94-V0, BLACK
 - M8 BOLT TORQUE (USING M8 BOLTS & LOCK WASHERS): 20Nm MAX.
 - MOUNTING TORQUE (USING M8 BOLTS & LOCK WASHERS): 20Nm MAX.
 - WIDTH OF TERMINAL SHOULD BE LESS THAN 25.4MM

NO	COMPONENT NO	DESCRIPTION	QTY/M	U/M
BILL OF MATERIAL				
UNLESS OTHERWISE SPECIFIED, DIMENSIONS ARE IN MILLIMETERS. DIMENSIONS IN BRACKETS [] ARE INCHES				
UNLESS OTHERWISE SPECIFIED, DIMENSIONS DO NOT INCLUDE PLATING.				
⊙	DENOTES CRITICAL CHARACTERISTICS.			
CPK	DENOTES CPK DIMENSIONS, -MINIMUM CPK VALUE			
ST	DENOTES A CHARACTERISTIC THAT PROVIDES AN INDICATION OF PROCESS PERFORMANCE. PROCEDURE FOR MEASUREMENT AND TRACKING TO BE DEFINED IN LITTELFUSE INSPECTION INSTRUCTIONS			
CP	DENOTES CP DIMENSIONS, -MINIMUM CP VALUE MUST BE WITHIN THE DIMENSIONAL LIMITATIONS SHOWN ON DRAWING AND INITIALLY LOCATED TO ALLOW FOR MAXIMUM TOOL LIFE			
COPIES TO		MATL SPEC		
1	9	18	FINISH	
2	10	19		
3	12	20		
4	13	21	DRW	GMB
5	14	23	DATE	11/1114
6	15	33	SCALE	1:1
7	16	43	CHK	DATE
8	17	53	APPD	DATE
TOLERANCES UNLESS OTHERWISE SPECIFIED (REF. ISO 2768-mK)				
DIMENSION	0.5 - 3	3 - 6	6 - 30	30 - 120
TOLERANCE	+0.1	+0.1	+0.2	+0.3
TITLE				
CF8 FUSE HOLDER 4-GANG				
LITTELFUSE		REVISION	DRWG. NO.	
DES PLAINES, ILLINOIS 60016		B	01-0799C001ZXS	

METRIC
ASSEMBLY

CAD GENERATED DRAWING - NO PENCIL CHANGES ALLOWED