

COVER OPENING POSITIONS

A E

LTR	DATE	REVISION	CHK	APD
A	06/10/10	SA329 - RELEASE 029810292XT GMB		

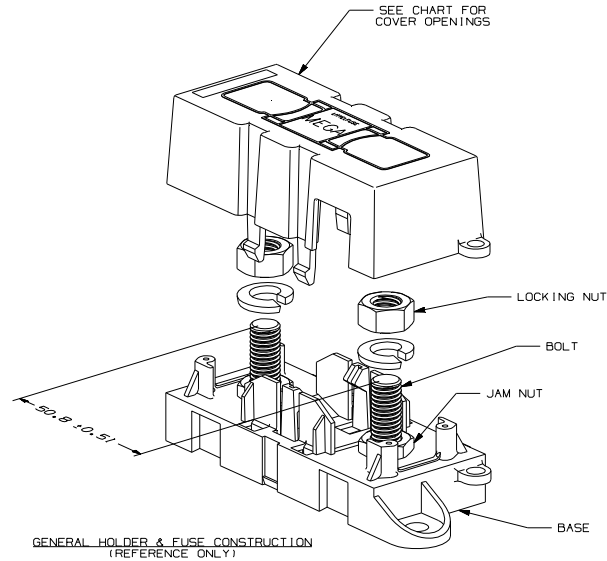
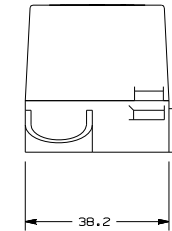
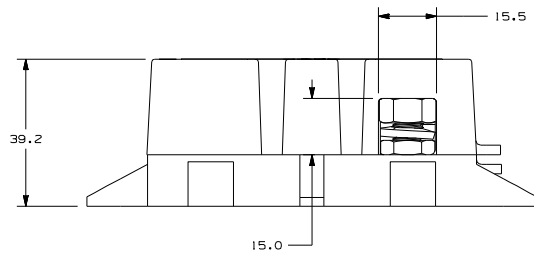
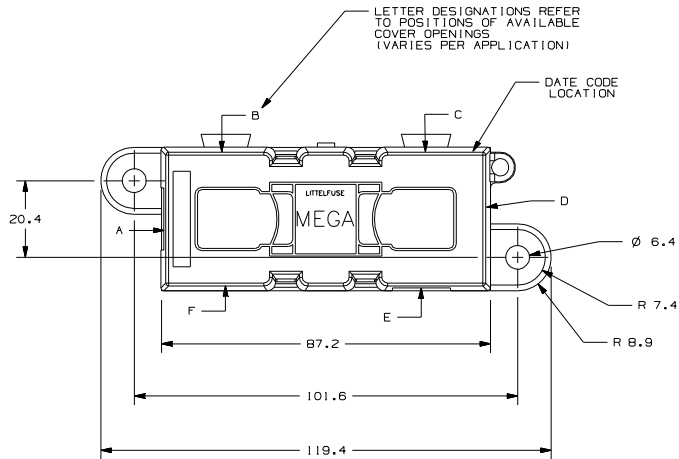

GENERAL NOTES:

- COVER RETENTION TEST A MINIMUM FORCE OF 2 LBS. IS REQUIRED TO REMOVE COVER WHEN IT IS SUSPENDED UPSIDE DOWN. FORCE SHALL BE APPLIED THROUGH THE INNER HOLES (2) IN BASE. USE FIXTURE #T-C403 TO SUPPORT PART.
- TORQUE REQUIREMENT FOR MEGA FUSE TERMINAL & CONNECTOR LOCKING NUTS TO BE: 8mm NUT - 12-18 NEWTON METERS (106-159 IN-LBS).
- HOLDER MEETS L/F VALIDATION TEST SPEC. VS-005002.

MATERIALS:

- BODY - GLASS FILLED THERMOPLASTIC
COLOR - BLACK
- COVER - THERMOPLASTIC
COLOR - BLACK
- WIRE TIE - THERMOPLASTIC
COLOR - BLACK
- STUDS & NUTS - M8 X 1.25 STEEL
ZINC PLATE WITH TRIVALENT CHROMATE, LEACHED AND SEALED, INTEGRAL TORQUE CONTROL LUBRICANT FINISH.
(MEETS 96 HR. ASTM STD. B-117 SALT SPRAY REQ.)

NO	COMPONENT NO	DESCRIPTION	QTY/M	U/M	
BILL OF MATERIAL					
UNLESS OTHERWISE SPECIFIED, DIMENSIONS ARE IN MILLIMETERS. DIMENSIONS IN BRACKETS [] ARE INCHES.					
UNLESS OTHERWISE SPECIFIED, DIMENSIONS DO NOT INCLUDE PLATING.					
⊙	DENOTES CRITICAL CHARACTERISTICS.				
CPK	DENOTES CPK DIMENSIONS. -MINIMUM CPK VALUE				
ST	DENOTES A CHARACTERISTIC THAT PROVIDES AN INDICATION OF PROCESS PERFORMANCE. PROCEDURE FOR MEASUREMENT AND TRACKING TO BE DEFINED IN LITTELFUSE INSPECTION INSTRUCTIONS				
CP	DENOTES CP DIMENSIONS. -MINIMUM CP VALUE MUST BE WITHIN THE DIMENSIONAL LIMITATIONS SHOWN ON DRAWING AND INITIALLY LOCATED TO ALLOW FOR MAXIMUM TOOL LIFE				
MATERIAL SPEC					
COPIES TO					
1	9	18			
2	10	19			
3	12	20			
4	13	21			
5	14	23			
6	15	33			
7	16	43			
8	17	53			
FINISH					
DRW	GMB	DATE	06/10/10	SCALE FULL	
CHK		DATE		SUPER DR	
APPD		DATE		FINISH GOOD WT	
GRAMS/PIECE					
TOLERANCES UNLESS OTHERWISE SPECIFIED (REF. ISO 2768-MK1)					
DIMENSION	0.5 - 0.9	0.9 - 1.6	1.6 - 30	30 - 120	120 - 400
TOLERANCE	±0.1	±0.1	±0.2	±0.3	±0.5
TITLE					
MEGAFUSE HOLDER					
METRIC					
LitteLfuse		REVISION	DRWG. NO.	OUTLINE	
DES PLAINES, ILLINOIS 60016		A	OL-029810292XT		

CAD GENERATED DRAWING - NO PENCIL CHANGES ALLOWED