

COVER OPENING POSITIONS
D F

LTR	DATE	REVISION	CHK	APD
A	10/20/08	000525ER- CREATED PRINT	GMB	

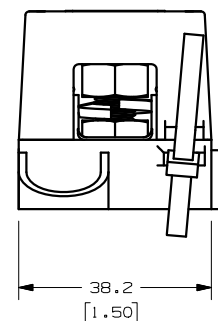
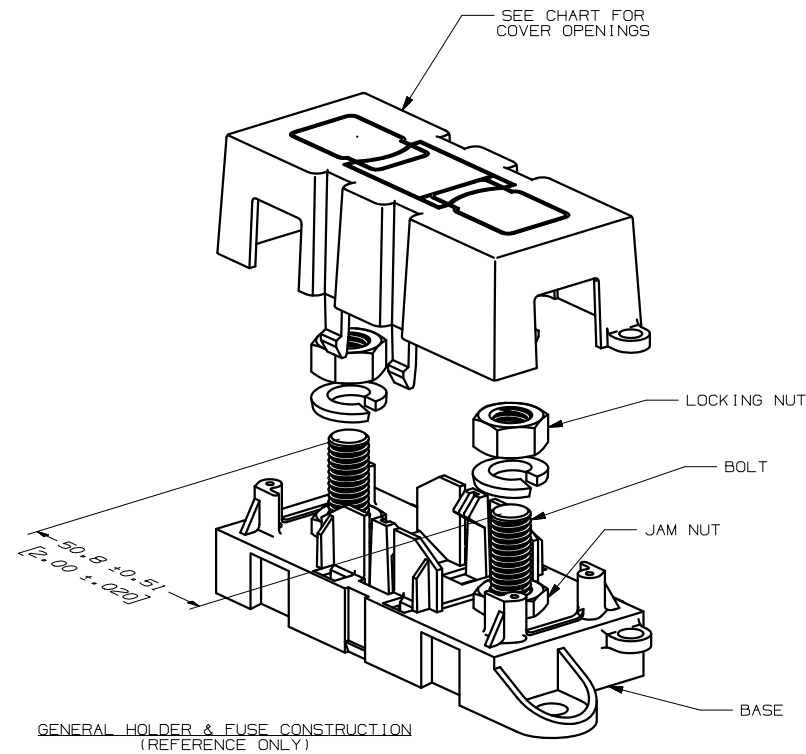
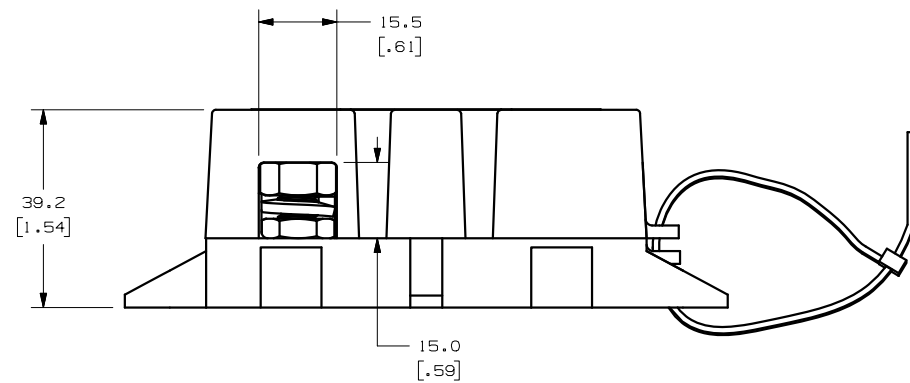
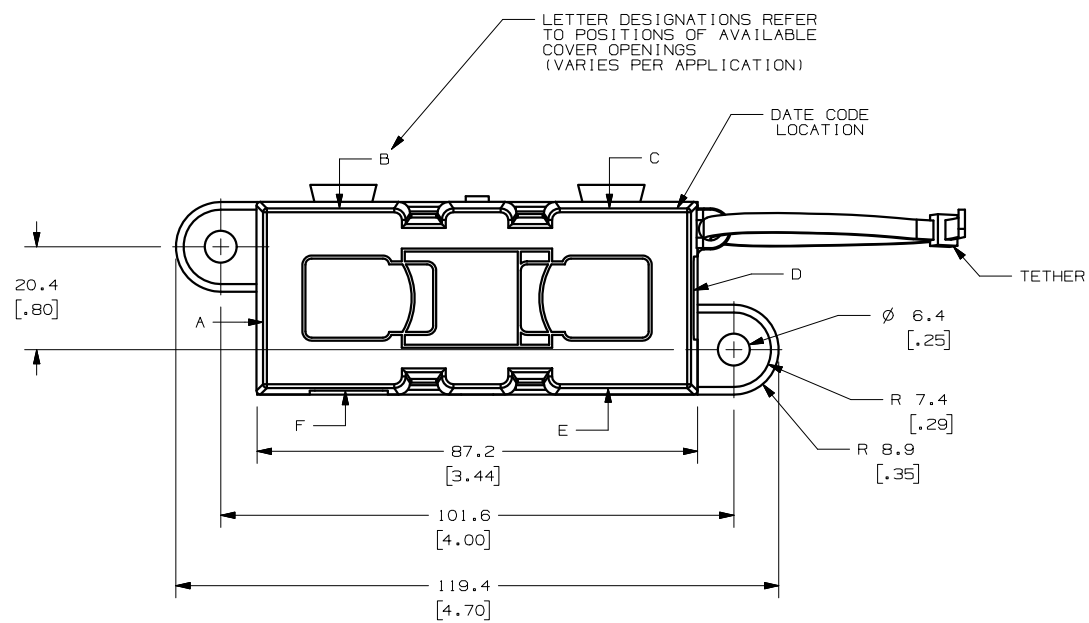

GENERAL NOTES:

- COVER RETENTION TEST A MINIMUM FORCE OF 2 LBS. IS REQUIRED TO REMOVE COVER WHEN IT IS SUSPENDED UPSIDE DOWN. FORCE SHALL BE APPLIED THROUGH THE INNER HOLES (2) IN BASE. USE FIXTURE #T-C403 TO SUPPORT PART.
- TORQUE REQUIREMENT FOR MEGA FUSE TERMINAL & CONNECTOR LOCKING NUTS TO BE: 8mm NUT - 12-18 NEWTON METERS (106-159 IN-LBS).
- HOLDER MEETS L/F VALIDATION TEST SPEC. VS-005002.

MATERIALS:

- BODY - GLASS FILLED THERMOPLASTIC
COLOR - BLACK
- COVER - THERMOPLASTIC
COLOR - BLACK
- WIRE TIE - THERMOPLASTIC
COLOR - BLACK
- STUDS & NUTS - M8 X 1.25 STEEL
ZINC PLATE WITH TRIVALENT CHROMATE, LEACHED AND SEALED,
INTEGRAL TORQUE CONTROL LUBRICANT FINISH.
(MEETS 96 HR. ASTM STD, B-117 SALT SPRAY REQ.)

NO	COMPONENT NO	DESCRIPTION	QTY/M	U/M
BILL OF MATERIAL				
UNLESS OTHERWISE SPECIFIED, DIMENSIONS ARE IN MILLIMETERS. DIMENSIONS IN BRACKETS [] ARE INCHES				
UNLESS OTHERWISE SPECIFIED, DIMENSIONS DO NOT INCLUDE PLATING.				
⊙	DENOTES CRITICAL CHARACTERISTICS.			
CPK	DENOTES CPK DIMENSIONS, -MINIMUM CPK VALUE			
ST	DENOTES A CHARACTERISTIC THAT PROVIDES AN INDICATION OF PROCESS PERFORMANCE. PROCEDURE FOR MEASUREMENT AND TRACKING TO BE DEFINED IN LITTELFUSE INSPECTION INSTRUCTIONS			
CP	DENOTES CP DIMENSIONS, -MINIMUM CP VALUE MUST BE WITHIN THE DIMENSIONAL LIMITATIONS SHOWN ON DRAWING AND INITIALLY LOCATED TO ALLOW FOR MAXIMUM TOOL LIFE			
MATERIAL SPEC				
COPIES TO				
1	9	18		
2	10	19	FINISH	
3	12	20		
4	13	21	DRW	GMB DATE 10/20/08 SCALE FULL
5	14	23	CHK	DATE SUPER DR
6	15	33	APPD	DATE FINISH GOOD WT
7	16	43		
8	17	53	GRAMS/PIECE	
TOLERANCE UNLESS OTHERWISE SPECIFIED				
ONE PLACE DEC +/- .3		THREE PLACE DEC +/- .100		
TWO PLACE DEC +/- .15		ANGULAR +/- 1°		
3RD ANGLE PROJECTION	TITLE MEGAFUSE HOLDER			
LITTELFUSE		REVISION	DRWG. NO.	OUTLINE
		A	02981024ZXT	

METRIC

CAD GENERATED DRAWING - NO PENCIL CHANGES ALLOWED