

4		3		2		1			
REV. DESCRIPTION				DATE		DESIGNED		APPROVED	
A		First issue of outline drawing		09/10/2019		Dal Molin		Tinto	

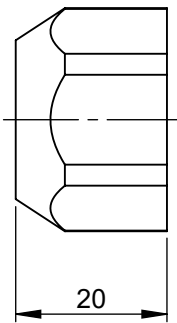

REFERENCE 1

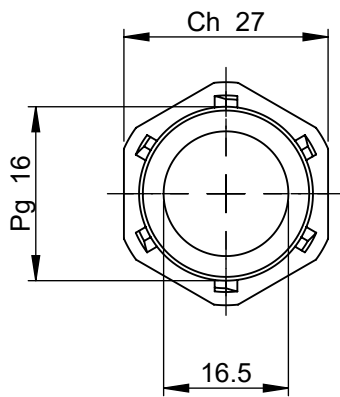
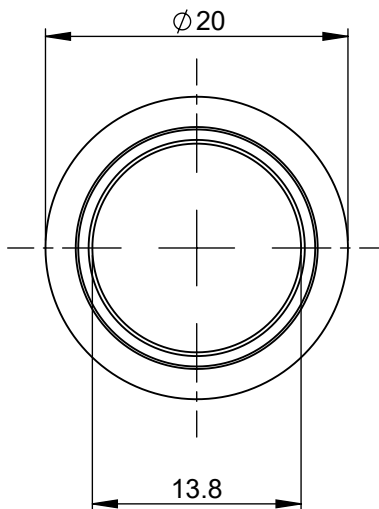
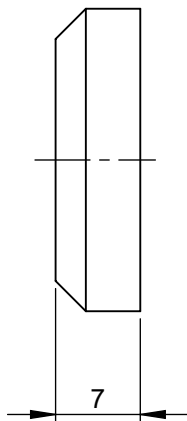

REFERENCE 2

2	Seal	/	Rubber CR
1	Nut Pg 16	/	Polyamide 6-15% GF
REF.	DESIGNATION	Q.TY	MATERIAL

SAP drawing number

DIMENSIONS AND TOLERANCES IN MILLIMETERS, DEFINED ACCORDING TO ISO 1101-2017.			
●	FIT/ FUNCTION CRITICAL CHARACTERISTICS SYMBOL		
<S>	SAFETY/ COMPLIANCE CRITICAL CHARACTERISTICS SYMBOL		
CPK	DENOTES CPK DIMENSIONS MINIMUM CPK VALUE		
ST	DENOTES A CHARACTERISTIC THAT PROVIDES AN INDICATION OF PROCESS PERFORMANCE.PROCEDURE FOR MEASUREMENTAND TRACKINGTO BE DEFINED IN LITTELFUSE INSPECTION INSTRUCTIONS		
CP	DENOTES CP DIMENSIONS, -MINIMUM CP VALUE MUST BE WITHIN THE DIMENSIONAL LIMITATIONS SHOWN ON DRAWING AND INITIALLY LOCATED TO ALLOW FOR MAXIMUM TOOL LIFE		
TOLERANCES UNLESS OTHERWISE SPECIFIED			
ONE PLACE DECIMAL ± 0.5		THREE PLACES DECIMAL ± 0.100	
TWO PLACES DECIMAL ± 0.20		ANGULAR ± 2°	
	NAME	DATE	 <b>Expertise Applied   Answers Delivered</b>
DRAWN	L. Dal Molin	10/9/2019	
CHECKED	-	-	
	-	-	
FORM NO: CVP-PE40-0014 REV A			TITLE
FIRST ANGLE PROJECTION			
DO NOT SCALE DRAWING			NUT AND SEAL FOR Ø16 CORRUGATED TUBE SIZE: A4 DWG. NO. OL-00601100 REV. A
SCALE 1:1		SHEET 1 OF 1	

THIS DRAWING AND THE INFORMATION CONTAINED WITHIN IT ARE CONFIDENTIAL AND MAY NOT BE COPIED OR DISCLOSED WITHOUT THE WRITTEN PERMISSION OF LITTELFUSE.