

MLA1812NR Varistor Series

Automotive Qualified > Surface Mount

HF **RoHS** **Pb**

Description

Littelfuse MLA1812NR Varistor Series is an AEC-Q200 qualified surface-mount Multilayer Varistor (MLV) with ultra-high surge current handling capability, which will protect integrated circuits and other components at the circuit board level to ensure reliable performance of the circuitry. It consists of stack of intercalating ceramic/electrode and nickel barrier termination.

Features

- High transient current absorption withstanding capability to meet IEC61000-4-5
- AEC-Q200 qualified
- High operating temperature: 125 °C
- RoHS compliant, Halogen-free, and Pb-free

Benefits

- Enhance product reliability and lifespan
- Meets requirements of auto graded product and suitable for automotive applications
- More reliable and suitable for high operating temperature applications
- Environment-friendly

Applications

- Automotive electronics (Infotainment, safety, body, and comfort)
- Industrial automation
- LED Lighting
- Building Applications

Web Resources



Download ECAD models, order samples, and find technical resources at www.littelfuse.com

Device Ratings and Characteristics

Part Number	Specifications (25 °C)						
	Maximum Continuous Working Voltage		Nominal Voltage Test Current @ 1 mA DC		Maximum Non-repetitive Surge Current (8/20 μs)	Maximum Clamping Voltage (8/20 μs)	Capacitance (Typical) 1KHz
	V_M (AC)	V_M (DC)	V_N (DC)	V_N (DC)	I_{TM}	V_C @ 5A	C_p
	(V)	(V)	Min (V)	Max (V)	(A)	(V)	pF
V14MLA1812NRAUTO	10	14	16	22	800	42	8400
V26MLA1812NRAUTO	18	26	31	38	800	62	3200
V30MLA1812NRAUTO	21	30	37	46	800	70	3950
V38MLA1812NRAUTO	30	38	46	54	800	80	2500
V45MLA1812NRAUTO	35	45	50	62	500	90	1800
V56MLA1812NRAUTO	40	56	67	84	800	135	1800
V65MLA1812NRAUTO	50	65	73	91	800	140	1500
V85MLA1812NRAUTO	60	85	90	110	400	145	1100
V100MLA1812NRAUTO	75	100	108	132	500	200	700

Notes:

1. RoHS compliant
2. Qualified based on AEC-Q200
3. Meet IEC61000-4-5 standard
4. Operating Ambient Temperature Range (TA): -40 °C to +125 °C
5. Storage temperature Range (on board): -40 °C to +125 °C
6. Moisture Sensitivity Level: Level 1
7. S=1000pcs/reel
8. Quick response time: <1 ns
9. Storage Time: 12 months max. Storage Temperature: 5 to 40 °C, Relative Humidity: 65% max.

MLA1812NR Varistor Series

Automotive Qualified > Surface Mount

Maximum Clamping Voltage

Part Number	10uA	100uA	1mA	10mA	100mA	1A	10A	100A	1000A
	10	100	1000	10000	100000	1000000	10000000	100000000	1000000000
V14MLA1812NRAUTO			21	23	27	31	38	109	
V26MLA1812NRAUTO			39	41	47	51	58	130	
V30MLA1812NRAUTO			45	48	55	61	68	141	
V38MLA1812NRAUTO			55	58	66	74	84	150	
V45MLA1812NRAUTO			62.5	66	72.5	79	89	158	
V56MLA1812NRAUTO			76	80.5	88	95	109	174	
V65MLA1812NRAUTO			86	91	98	105	119	186	
V85MLA1812NRAUTO			108	114	122	129	146	215	
V100MLA1812NRAUTO			126	134	144	154	174	249	

Limit V-I Characteristics

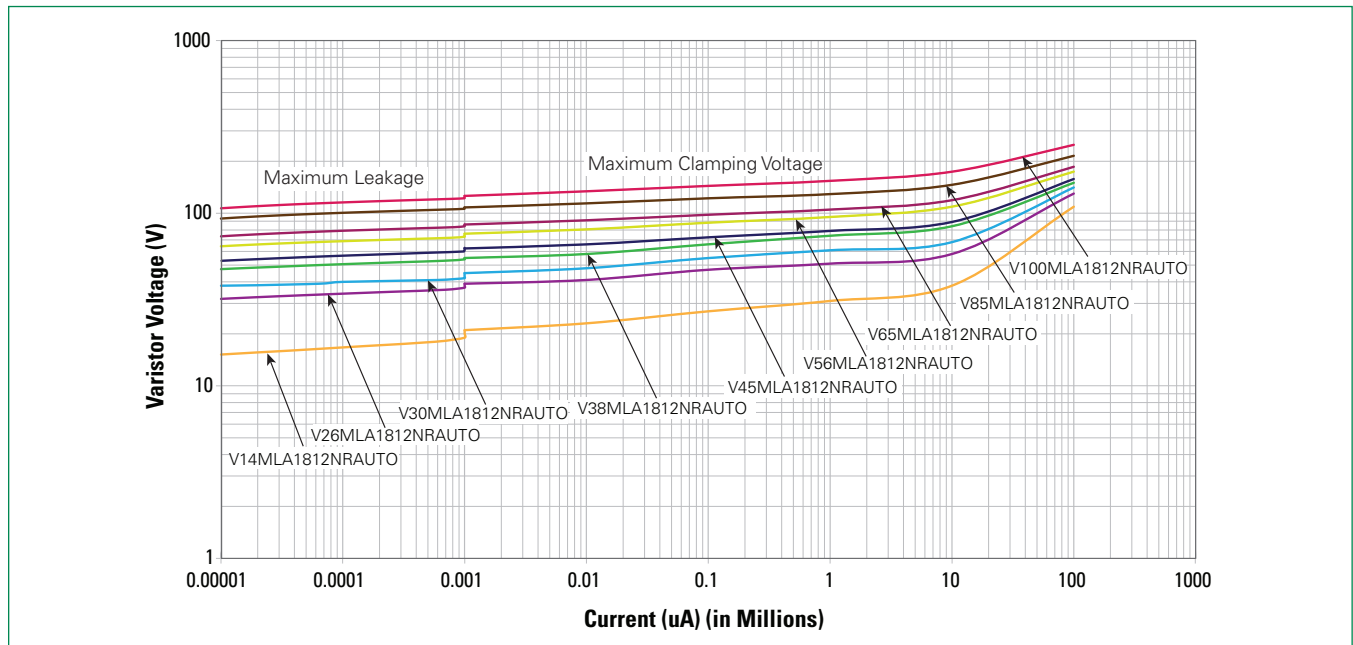

MLA1812NR Varistor Series

Automotive Qualified > Surface Mount

Mechanical Dimensions

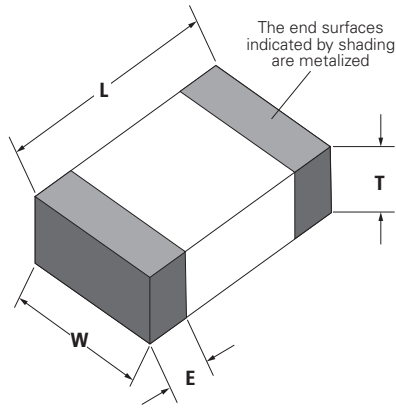

Dimension	Specification (mm)
L	4.50 +/- 0.4
W	3.20 +/- 0.30
T	2.5 Max
E	0.60 +/- 0.30

Recommended Pad Size

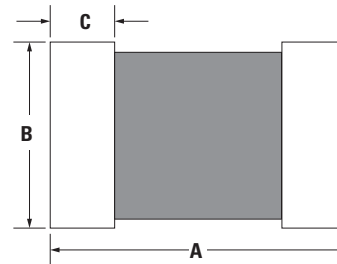

Dimension	Specification (mm)
A	6.0
B	3.6
C	1.5

Soldering Parameters

Reflow Condition		Pb-free assembly
Pre Heat	- Temperature Min ($T_{s(min)}$)	150 °C
	- Temperature Max ($T_{s(max)}$)	200 °C
	- Time (Min to Max) (t_s)	60–180 secs
Average Ramp-Up Rate ($T_{s(max)}$ to T_p)		3 °C / second max.
Reflow	- Temperature (T_L) (Liquidus)	217 °C
	- Temperature (t_L)	60–150 secs
Peak Temperature (T_p)		260+0 / -5 °C
Time within 5 °C of actual peak Temperature (t_p)		20–40 seconds
Ramp-down Rate		6 °C / second max.
Time 25 °C to peak Temperature (T_p)		8 minutes max.
Do not exceed		260 °C

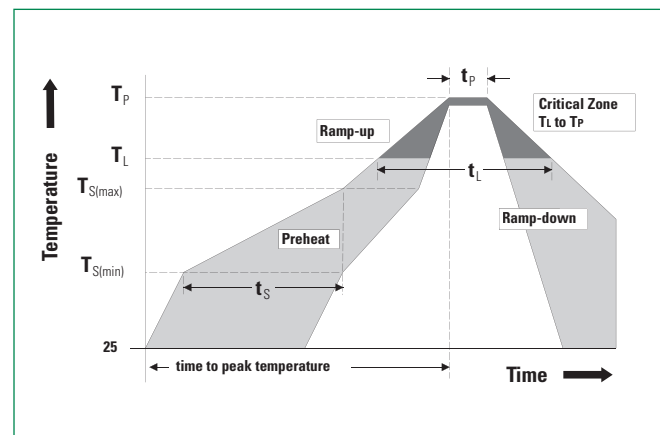

MLA1812NR Varistor Series

Automotive Qualified > Surface Mount

Reel Specifications (Unit: mm)

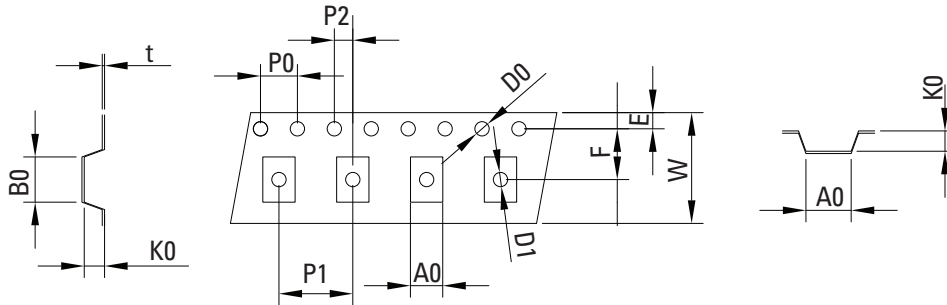

Type	W	E	F	D0	D1	P0	P1	P2	B0	A0	K0	t
1812	12.00 ±0.15	1.75 ±0.10	5.5 ±0.10	1.55 ±0.10	1.55 ±0.10	4.00 ±0.10	8.00 ±0.10	2.00 ±0.10	4.90 ±0.15	3.50 ±0.10	2.2 ±0.10	0.25 ±0.05

Tape Specifications (Unit: mm)

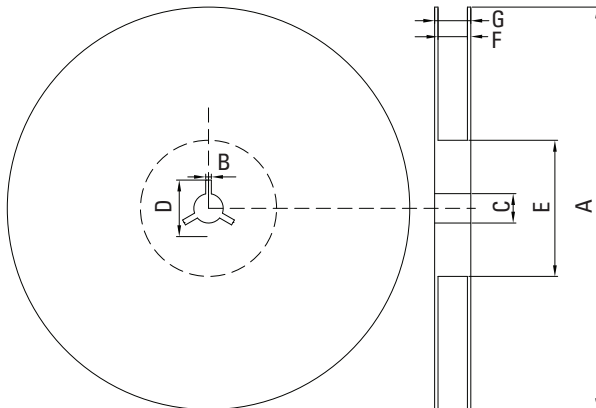

Type	A	B	C	D	E	F	G
1812	178.0±1.0	2.5±0.5	13.0±0.5	25.0±0.5	60.2±0.5	13.0±0.5	16.0±0.5

Disclaimer Notice - Information furnished is believed to be accurate and reliable. However, users should independently evaluate the suitability of and test each product selected for their own applications. Littelfuse products are not designed for, and may not be used in, all applications. Read complete Disclaimer Notice at <http://www.littelfuse.com/disclaimer-electronics>.