

AC Controller Modules

$$I_{RMS} = 175 \text{ A}$$

$$I_{TAVM} = 80 \text{ A}$$

$$V_{RRM} = 1200/1600 \text{ V}$$

V_{RSM}	V_{RRM}	Typ
V_{DSM}	V_{DRM}	
V	V	
1300	1200	MMO 175-12io7
1700	1600	MMO 175-16io7

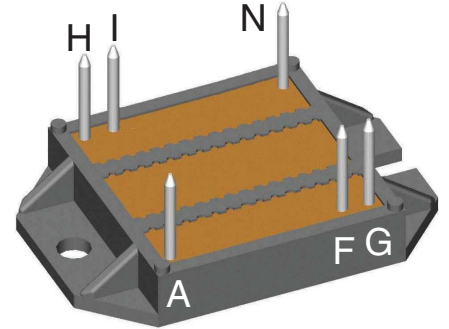
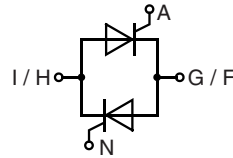

Preliminary Data

Symbol	Conditions	Maximum Ratings	
I_{RMS}	$T_C = 85^\circ\text{C}$; 50-400 Hz (per single controller)	175	A
I_{TRMS}		125	A
I_{TAVM}	$T_C = 85^\circ\text{C}$; 180° sine	80	A
I_{TSM}	$T_{VJ} = 45^\circ\text{C}$; $t = 10 \text{ ms}$ (50 Hz)	1500	A
	$V_R = 0$; $t = 8.3 \text{ ms}$ (60 Hz)	1600	A
I^2t	$T_{VJ} = 125^\circ\text{C}$; $t = 10 \text{ ms}$ (50 Hz)	1350	A
	$V_R = 0$; $t = 8.3 \text{ ms}$ (60 Hz)	1450	A
$(di/dt)_{cr}$	$T_{VJ} = 45^\circ\text{C}$; $t = 10 \text{ ms}$ (50 Hz)	11 200	A ² s
	$V_R = 0$; $t = 8.3 \text{ ms}$ (60 Hz)	10 750	A ² s
$(di/dt)_{cr}$	$T_{VJ} = 125^\circ\text{C}$; $t = 10 \text{ ms}$ (50 Hz)	9 100	A ² s
	$V_R = 0$; $t = 8.3 \text{ ms}$ (60 Hz)	8 830	A ² s
$(di/dt)_{cr}$	$T_{VJ} = 125^\circ\text{C}$; $f = 50 \text{ Hz}$; $t_p = 200 \mu\text{s}$; $V_D = 2/3 V_{DRM}$; $I_G = 0.45 \text{ A}$; $di_G/dt = 0.45 \text{ A}/\mu\text{s}$	150	A/ μs
	repetitive, $I_T = 80 \text{ A}$		
$(dv/dt)_{cr}$	non repetitive, $I_T = I_{TAVM}$	500	A/ μs
$(dv/dt)_{cr}$	$T_{VJ} = 125^\circ\text{C}$; $V_D = 2/3 V_{DRM}$; $R_{GK} = \infty$; method 1 (linear voltage rise)	1000	V/ μs
P_{GM}	$T_{VJ} = 125^\circ\text{C}$; $t_p = 30 \text{ ms}$	10	W
	$I_T = I_{T(AV)M}$; $t_p = 300 \text{ ms}$	5	W
P_{GAVM}		0.5	W
V_{RGM}		10	V
T_{VJ}		-40...+150	°C
T_{VJM}		150	°C
T_{stg}		-40...+125	°C
V_{ISOL}	50/60 Hz, RMS; $t = 1 \text{ min}$	2500	V~
	$I_{ISOL} \leq 1 \text{ mA}$; $t = 1 \text{ s}$	3000	V~
M_d	Mounting torque (M4)	1.5 - 2.0	Nm
		14 - 18	lb.in.
Weight	Typical including screws	18	g

Features

- Thyristor controller for AC (circuit W1C acc. to IEC) for mains frequency
- Isolation voltage 3000 V~
- Planar glass passivated chips
- Low forward voltage drop
- Leads suitable for PC board soldering

Applications

- Switching and control of single and three phase AC circuits
- Light and temperature control
- Softstart AC motor controller
- Solid state switches

Advantages

- Easy to mount with two screws
- Space and weight savings
- Improved temperature and power cycling
- High power density
- Small and light weight

Data according to IEC 60747 and refer to a single diode unless otherwise stated.

Disclaimer Notice

Information furnished is believed to be accurate and reliable. However, users should independently evaluate the suitability of and test each product selected for their own applications. Littelfuse products are not designed for, and may not be used in, all applications. Read complete Disclaimer Notice Disclaimer Notice at www.littelfuse.com/disclaimer-electronics.

IXYS reserves the right to change limits, test conditions and dimensions.

20200120c

Symbol	Conditions	Characteristic Values	
		typ.	max.
I_D, I_R	$V_R / V_D = V_{RRM} / V_{DRM}$	$T_{VJ} = 125^\circ\text{C}$	5 mA
V_T	$I_T = 200 \text{ A}$	$T_{VJ} = 25^\circ\text{C}$	1.57 V
V_{T0}	For power-loss calculations only		0.85 V
r_t			3.70 mΩ
V_{GT}	$V_D = 6 \text{ V}$	$T_{VJ} = 25^\circ\text{C}$	1.5 V
		$T_{VJ} = -40^\circ\text{C}$	1.6 V
I_{GT}	$V_D = 6 \text{ V}$	$T_{VJ} = 25^\circ\text{C}$	100 mA
		$T_{VJ} = -40^\circ\text{C}$	200 mA
V_{GD}	$V_D = \frac{2}{3} V_{DRM}$	$T_{VJ} = 125^\circ\text{C}$	0.2 V
I_{GD}			10 mA
I_L	$t_p = 10 \mu\text{s};$ $I_G = 0.45 \text{ A}; di_G/dt = 0.45 \text{ A}/\mu\text{s}$	$T_{VJ} = 25^\circ\text{C}$	450 mA
I_H	$V_D = 6 \text{ V}; R_{GK} = \infty;$	$T_{VJ} = 25^\circ\text{C}$	200 mA
t_{gd}	$V_D = \frac{1}{2} V_{DRM}$ $I_G = 0.45 \text{ A}; di_G/dt = 0.45 \text{ A}/\mu\text{s}$	$T_{VJ} = 25^\circ\text{C}$	2 μs
R_{thJC}	per thyristor; DC current		0.50 K/W
R_{thCH}		0.12	K/W
R_{thJC}	per module		0.25 K/W
R_{thCH}		0.06	K/W
d_s	Creeping distance on surface		11.2 mm
d_A	Creepage distance in air		5.0 mm
a	Maximum allowable acceleration		50 m/s ²

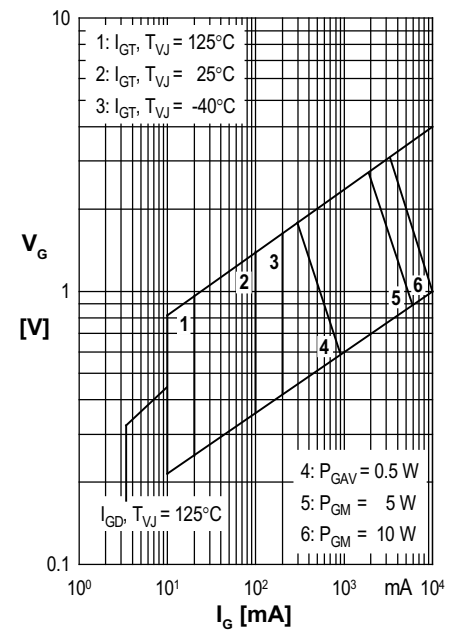

Fig. 1 Gate trigger characteristics

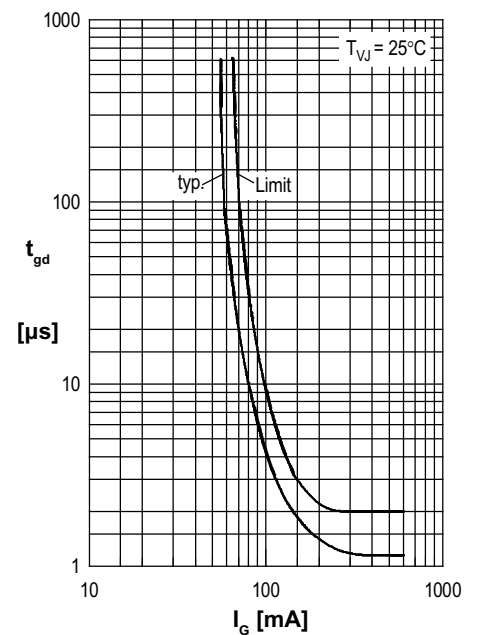
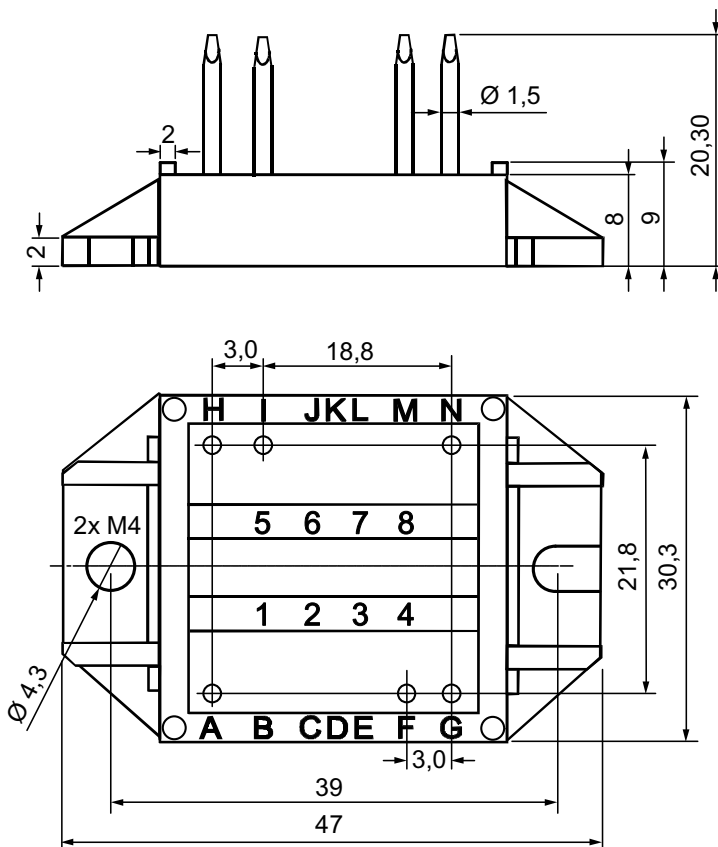
Dimensions in mm (1 mm = 0.0394")

Fig. 2 Gate trigger delay time