

Bridging the Gap Between Modules and Discretes

ISOPLUS-SMPD™ & ISOPLUS™ i4-PAC™

Ideal for EV charging infrastructure, medical, and industrial applications, our ISOPLUS-SMPD™ and ISOPLUS™ i4-PAC™ package solutions bridge the gap between modules and discretes, providing a range of advantages and value additions:

- Integrated Direct Copper Bonded (DCB) isolation delivers best-in-class reliability under power and temperature cycling via the IXYS proprietary DCB production and discrete assembly with 2.5 kV minimum isolation voltage
- Available in a variety of technologies, such as Si/SiC MOSFET, IGBT, Diode, Thyristor, TRIAC, or a customized combination with different voltage classes: SMPD™ (40 V to 3000 V) and i4-PAC (100 V to 4500 V)
- Offered in several topologies, including single switch, phase leg, H-Bridge, and others
- The SMPD allows fully automated pick and place as well as standard reflow soldering for ease of manufacturing
- Optimized use of DCB space in the component improves the power density and thermal management

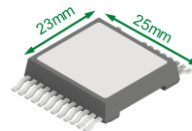

SMPD™-X

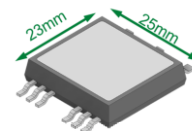

SMPD™-B

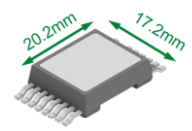

miniSMPD™

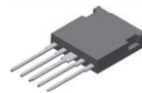

i4-PAC (5)

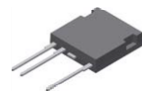

i4-PAC (3asym)

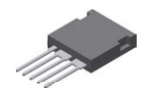

i4-PAC (5HC)



i4-PAC (3sym)

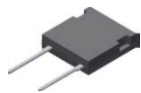

i4-PAC (2sym)

Mounting Efforts Reduction with Improved Thermal Performance

(Example of ISOPLUS-SMPD™) The 3-Phase PFC stage in EV charger: P=22 kW, I_{Dms}=32 A 3-Phase, f_{sw}=25 kHz, T_{Sink}=65 °C

While every design is a multifaceted optimization exercise, this table illustrates that when compared to a standard TO-247-based solution the SMPD device presents characteristics that would improve manufacturability and thermal management for the given design example.

3 - Phase PFC Stage	SiC MCB60P1200TLB: SMPD™	SiC LSIC1M0120G0025: TO-247
Total Number of Devices	3	12
Number of Isolation Pad	No Need	12 (e.g. Sil-Pad® 2000)
Mounting Efforts	3 Clamps/Counter Bracket	12 Screws, 12 Washers
Thermal Resistance Junction-to-Heatsink R _{th,JH} [K/W]	0.65	1.3

Power Stage Building Blocks Using SMPD™ and i4-PAC™

(EV Charging Infrastructure Example)

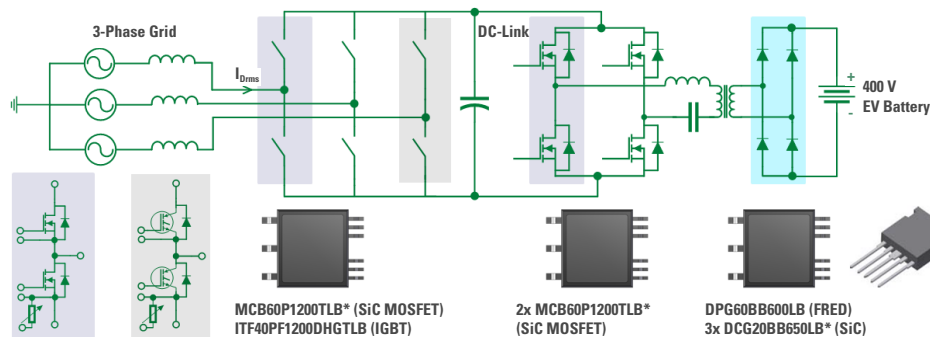

* - Under Development