

DCNEVT400 SERIES HIGH CURRENT HIGH VOLTAGE DC CONTACTOR RELAY

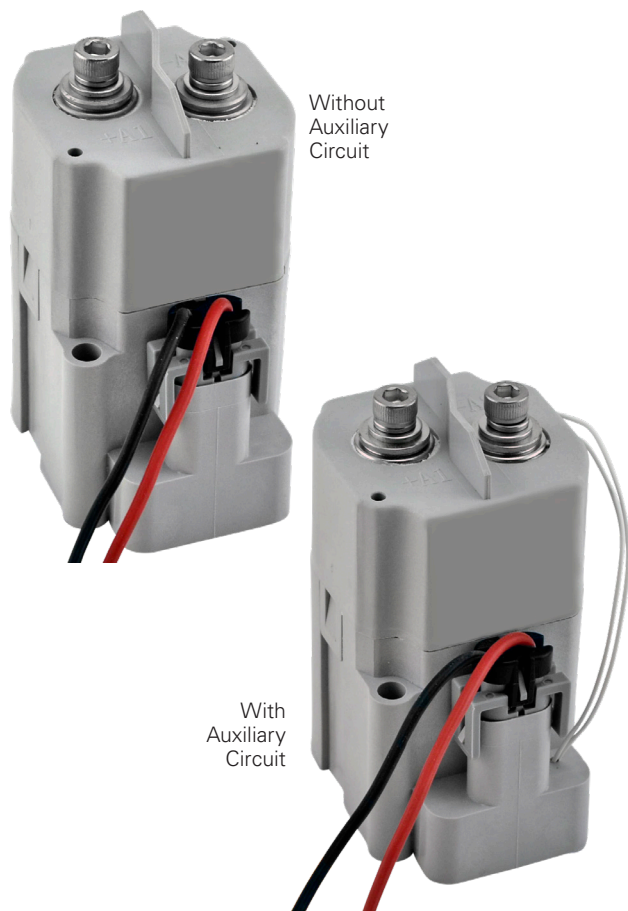

Specifications Overview

Amperage:	400A Continuous Carry
Housing:	Nylon UL 94-V0
Voltage Rating:	1800V DC
Connectors:	Sealed Wire Connector (Included) Aptiv P/N 12162017
Ingress Protections:	IP54
Operating Temperature:	-40°C to 85°C
Circuitry:	SPST NO
Coil Voltage:	B: 12V DC Nominal, 9 - 16V DC Working C: 24V DC Nominal, 18 - 28V DC Working
Max Coil Inrush Current:	B: 2.8A Max to Coil C: 1.8A Max to Coil
Size:	Reference Dimensions on Page 2
Mounting:	M6
Mounting Bolt Torque:	1.7-3.3 Nm (15-30 in-lb)
Contact Torque:	6-8 Nm (53-70 in-lb)
Terminals:	M6 Silver Plated Copper
Approvals:	UL File No. E510407 Recognized

Description

High current and high voltage DC contactor relays for electric vehicle, hybrid electric vehicle, circuit protection, battery switch, and main power break. The Coil Economizer greatly reduces coil power and heating after the contactor is energized. Once the contactor is energized, it takes minimal coil power to keep the contacts closed due to Pulse Width Modulation (PWM) reducing the average power delivered by pulsing the electrical signal. Utilizes polarized contacts for optimum performance amidst polarized electrical loads.

Web Resources

Download 2D print and technical resources at:
littelfuse.com/DCNEVT400

Ordering Information

PART NUMBER	DESCRIPTION	COIL VOLTAGE 12V DC	COIL VOLTAGE 24V DC	BOTTOM MOUNT	AUXILIARY CONTACT SPST-NO
DCNEVT400-B	High Voltage DC Contactor Relay Bottom Mount with Polar Load Terminals	●		●	
DCNEVT400-BA	High Voltage DC Contactor Relay Bottom Mount with Auxiliary Circuit with Polar Load Terminals	●		●	●
DCNEVT400-C	High Voltage DC Contactor Relay Bottom Mount with Polar Load Terminals		●	●	
DCNEVT400-CA	High Voltage DC Contactor Relay Bottom Mount with Auxiliary Circuit with Polar Load Terminals		●	●	●

* Box Packaging Available

Features and Benefits

- High current (400A) and high voltage (1800V) contactor for EV applications
- Coil Enonomizer greatly reduces coil power and heating
- Hermetically sealed contact chamber to protect all moving parts
- Sealed control wire connector included
- Able to handle harsh environments
- Designed and manufactured under the IATF16949 certification for Automotive Quality Systems.
- Designed specifically for automotive applications.

Applications

- Battery Electric Vehicles
- Hybrid Electric Vehicles
- Material Handling
- Electric Maintenance and Transport Vehicles
- Industrial Applications

DCNEVT400 SERIES HIGH CURRENT HIGH VOLTAGE DC CONTACTOR RELAY

Dimensions in MM

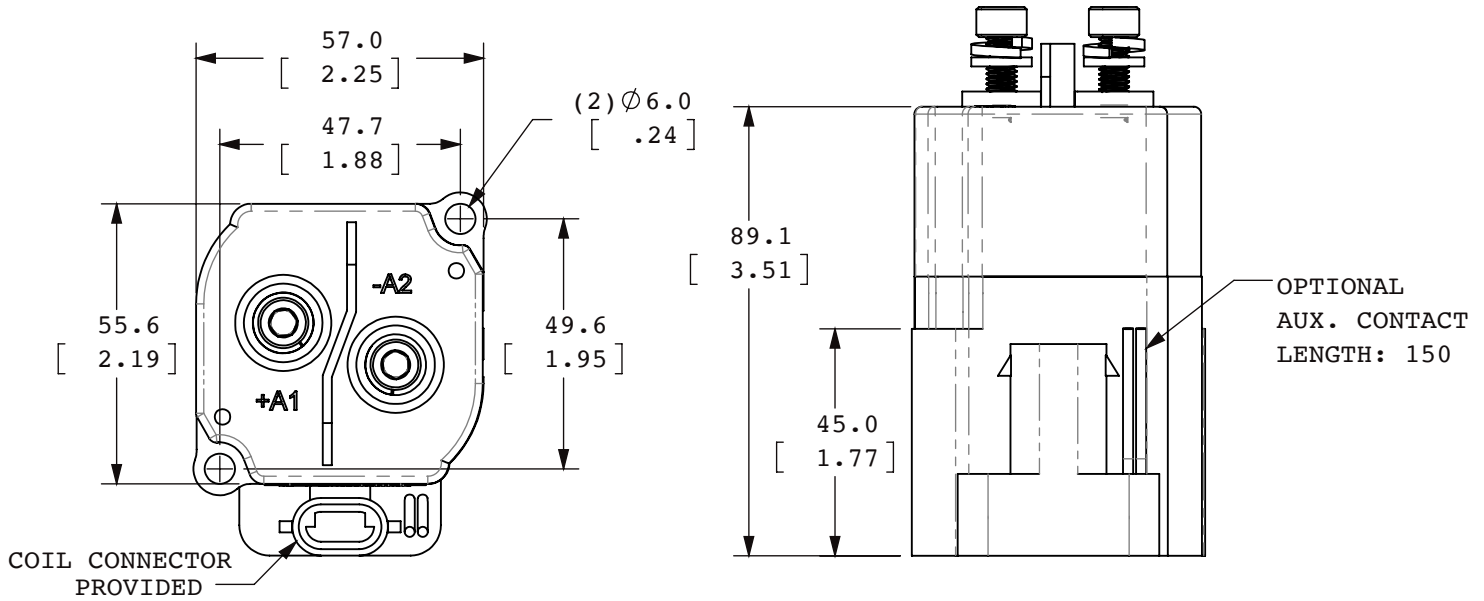

Capacitive Make Test Curve

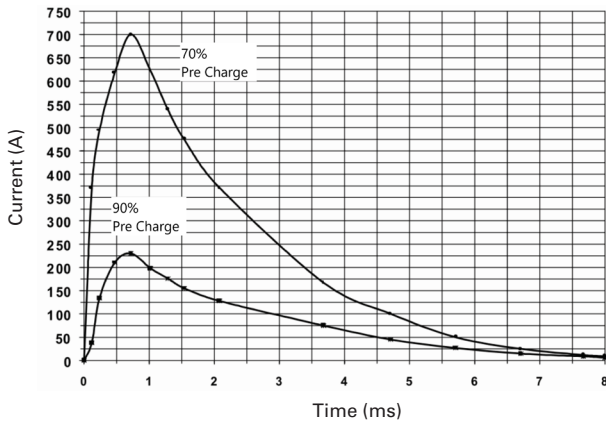

Estimated Make Break Chart

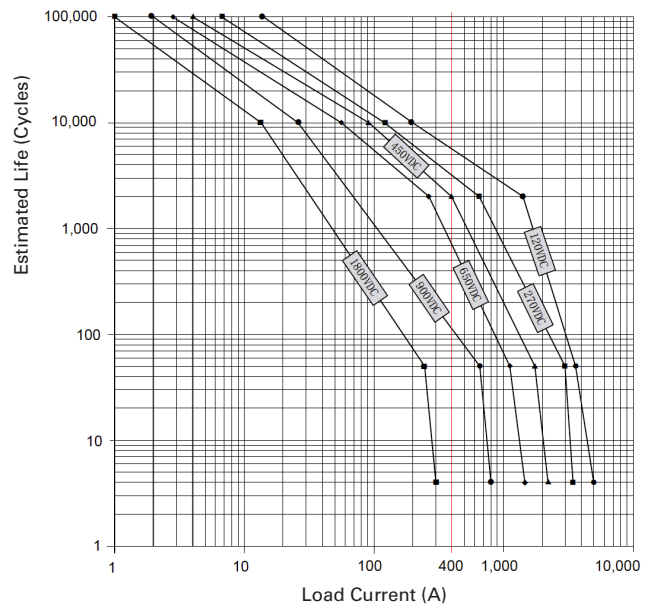

Test run under controlled conditions. User to verify in actual application.

Electrical Diagram

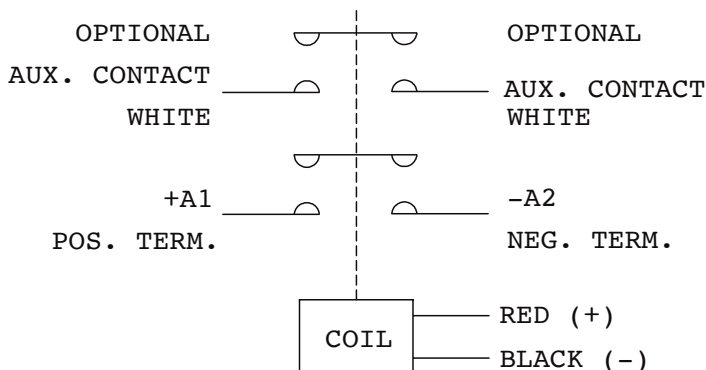

DCNEVT400 SERIES HIGH CURRENT HIGH VOLTAGE DC CONTACTOR RELAY

Performance Data

MAIN CONTACT	
Contact arrangement	1 Form X (SPST-NO, DM)
Rated Operating Voltage	12-1,800VDC
Continuous (Carry) Current	400A*1
Short term Carry Current	450A (6.5 minutes) *2
Max short circuit current	2,300A @ 450VDC (1 cycle)
Dielectric Withstanding Voltage	Between open contacts: 4,000VDC (leakage ≤1mA) Between contact and coil: 2,200Vrms (leakage ≤1mA)
Insulation Resistance	Terminal to Terminal/Terminal to coil New: Min 100 MΩ @500Vdc
Voltage Drop (@350A)	≤120mV

1: Current is relevant to cross-sectional area of conductor.
2: Ambient Temperature +65°C

COIL DATA		
Voltage rating	12Vdc	24Vdc
Pickup voltage (25°C)	10Vdc	19Vdc
Dropout voltage (25°C)	4Vdc	9Vdc
Inrush current @ nominal voltage	2.8A	1.8A
Holding current @ nominal voltage	0.40A	0.11A

MAX. BREAKING LIMIT	MAX. SHORT CIRCUIT
3,500A @ 750VDC, 1 cycle	4,000A, 1 sec

LIFE	
Electrical Life	See estimated make break chart
Mechanical life	200,000 cycles

OPERATE / RELEASE TIME	
Close (includes bounce)	18ms, Max.
Bounce (after close)	5ms, Max.
Release	15ms, Max.

ENVIRONMENTAL DATA	
Shock, 11ms ½ sine, operating	20G Peak
Vibration, Sine, Peak, 20G	10—1,000Hz
Operating Ambient Temperature	-40 to +85°C
Weight	1.76 lb (0.8 kg)
Altitude	<4000m
Noise (@100mm)	70dB(a)

AUX. CONTACT	
Aux. Contact Arrangement	SPST-NO (1 Form A)
Aux. Contact Rating (Max Wattage)	10W
Aux. Contact Rating (Max Voltage)	100 VDC
Aux. Contact Resistance (Max)	500mΩ

Current vs Time Curve

Carry Current vs Time (85°C)

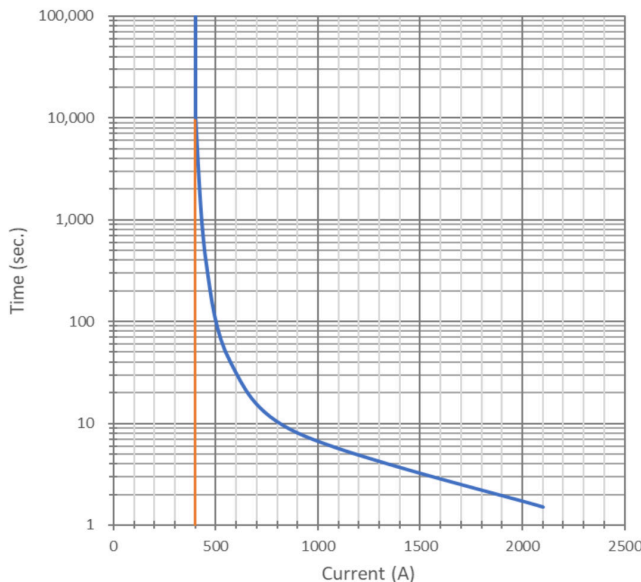

Copper Conductor: 100mm²

Application Note:

- Be sure to use washer to prevent screws from loosening, all the terminals or copper bar must be in direct contact with the contactor's terminals.
 - Contact Terminal Torque: 53 - 70 lb.in (6 - 8 N.m)
 - Mounting Torque: 15 - 30 lb.in (1.7 - 3.3 N.m)
- Contact terminals are polarized so refer to drawing during connecting. There is a reverse surge absorption circuit so that it is not necessary to use a surge protective device.
- Do not use if dropped.
- Avoid installing in a strong magnetic field (close to a transformer or magnet), or near a heat source.
- Electrical life
Use per load capability and life cycle limits so as not to cause a function failure (treat the contactor as a product with specified life and replace it when necessary). It is possible to make parts burn around the contactor once operating failure occurs. It is necessary to take layout considerations into account and to make sure power shall be cut off within 1 second.
- Avoid debris or oil contamination of the main terminals to optimize contact and avoid excess heat generation.