

Ø30.94 ± 0.381
[Ø1.218 ± 0.015]

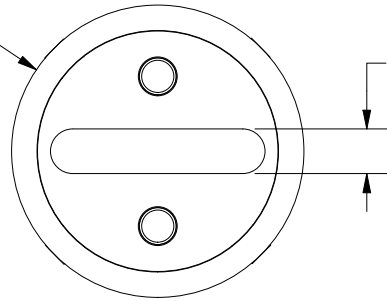

4.75 ± 0.15
[0.187 ± 0.006]

8.74 ± 0.25
[0.344 ± 0.010]

22.73 ± 0.89
[0.895 ± 0.035]

10.51 ± 0.25
[0.414 ± 0.010]

70.32 ± 1.60
[2.768 ± 0.063]

53.98
[2.125]

73.86 ± 1.60
[2.908 ± 0.063]

92.08 ± 1.60
[3.625 ± 0.063]

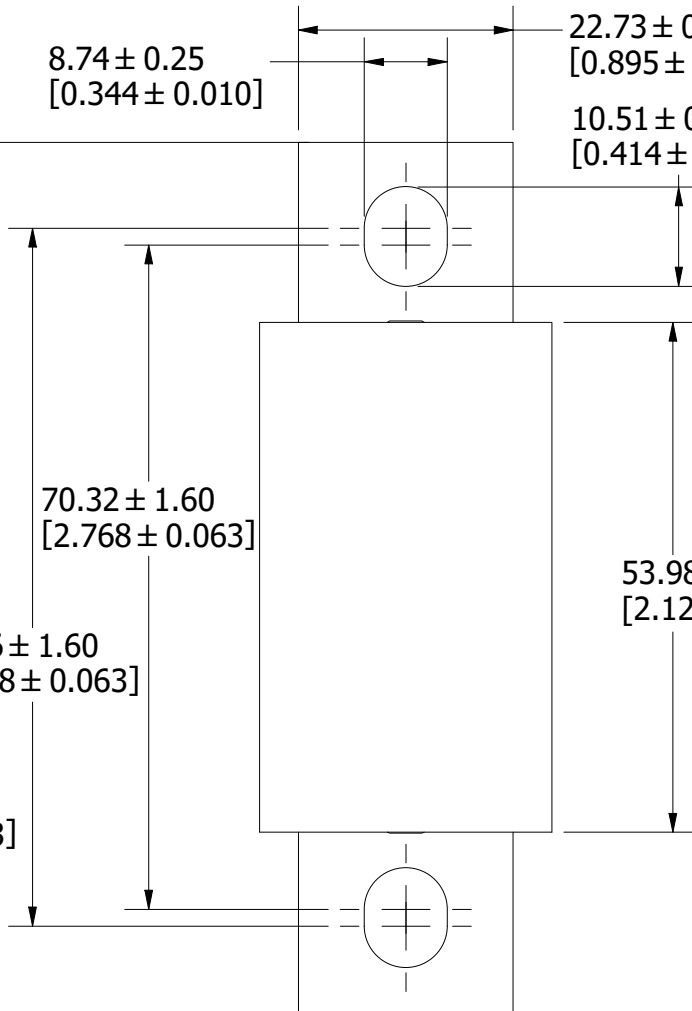

REVISION		
REV	DATE	DESCRIPTION
A	6/29/23	526672GCP - RELEASE MRY

1	COMPONENT NO	DESCRIPTION	QTY/M	U/M
---	--------------	-------------	-------	-----

BILL OF MATERIAL

<S>	CRITICAL CHARACTERISTIC FOR PART SAFETY/COMPLIANCE
●	DENOTES CRITICAL CHARACTERISTICS.
CPK	DENOTES CPK DIMENSIONS, -MINIMUM CPK VALUE
⊠	DENOTES A CHARACTERISTIC THAT PROVIDES AN INDICATION OF PROCESS PERFORMANCE. PROCEDURE FOR MEASUREMENT AND TRACKING TO BE DEFINED IN LITTELFUSE INSPECTION INSTRUCTIONS.
CP	DENOTES CP DIMENSIONS, -MINIMUM CP VALUE MUST BE WITHIN THE DIMENSIONAL LIMITATIONS SHOWN ON DRAWING AND INITIALLY LOCATED TO ALLOW FOR MAXIMUM TOOL LIFE.

A

MATL SPEC	FINISH		
DRW JMoler	DATE 6/21/2023	SCALE NTS	FINISH GOOD WT GRAMS/PIECE

UNLESS OTHERWISE SPECIFIED, DIMENSIONS ARE IN MILLIMETERS, DIMENSIONS IN BRACKETS [] ARE INCHES DIMENSIONING AND DO NOT INCLUDE PLATING. TOLERANCING TO BE INTERPRETED IN ACCORDANCE WITH ANSI Y14.5M-1994

3RD ANGLE PROJECTION	
----------------------	--

TITLE L50QS 125-200A OUTLINE

 Littelfuse CHICAGO, ILLINOIS 60631	REVISION A	DRWG NO. OL-L50QS200	SHEET 1 OF 1
--	----------------------	--------------------------------	--------------