

# Installation Instructions for ISS-102AA-DCS Intrinsically-Safe Switch

**WARNING:** TO PREVENT IGNITION OF FLAMMABLE OR COMBUSTABLE ATMOSPHERES, DISCONNECT POWER FROM THE SYSTEM PRIOR TO INSTALLATION OR SERVICE.

**CAUTION:** Installation must comply with all national, state, and local codes. Installation of this equipment should only be performed by personnel trained in intrinsically-safe systems. Improper installation may result in serious injury or damage. Before proceeding with installation, read and understand these instructions completely.

The ISS-102 Isolated Switch is UL913 listed (E233355) as an associated apparatus for interfacing between hazardous and non-hazardous areas. The ISS-102 must be installed in a non-hazardous area. Follow SymCom's Control Drawing ISS-102AA on the back of this sheet for proper installation.

All wiring connected to a hazardous location must be separated from all non-intrinsically-safe wiring. Description of special wiring methods can be found in the National Electrical Code ANSI/NFPA 70, Article 504 Intrinsically-Safe Systems. Check your state and local codes for additional requirements.

**WARNING:** REMOVE POWER FROM THE SYSTEM PRIOR TO INSTALLING OR SERVICING THE ISS-102.

## Installation:

1. Mount the ISS-102 in a non-hazardous location on 35mm DIN rail, or by installing two #6-#8 screws into the surface mounting holes provided.
2. Connect wiring per SymCom's Control Drawing ISS-102AA (on following page). Follow all hazardous code requirements while installing wiring to switch input terminals.

## Operation:

The ISS-102AA-DCS is a dual-channel switch with two form A output relays. The input resistance threshold is fixed at 100kΩ. Each output contact closes upon closure (input resistance <100kΩ) of its associated input switch. Resistance probes or switches can be used on the inputs.

The ISS-102AA-DCS has a .5-second debounce time delay—the output contact will not change states until a condition exists for .5 second—to prevent nuisance actuation and rapid cycling.

Green LEDs illuminate on the ISS-102AA-DCS when the associated output relay is energized.

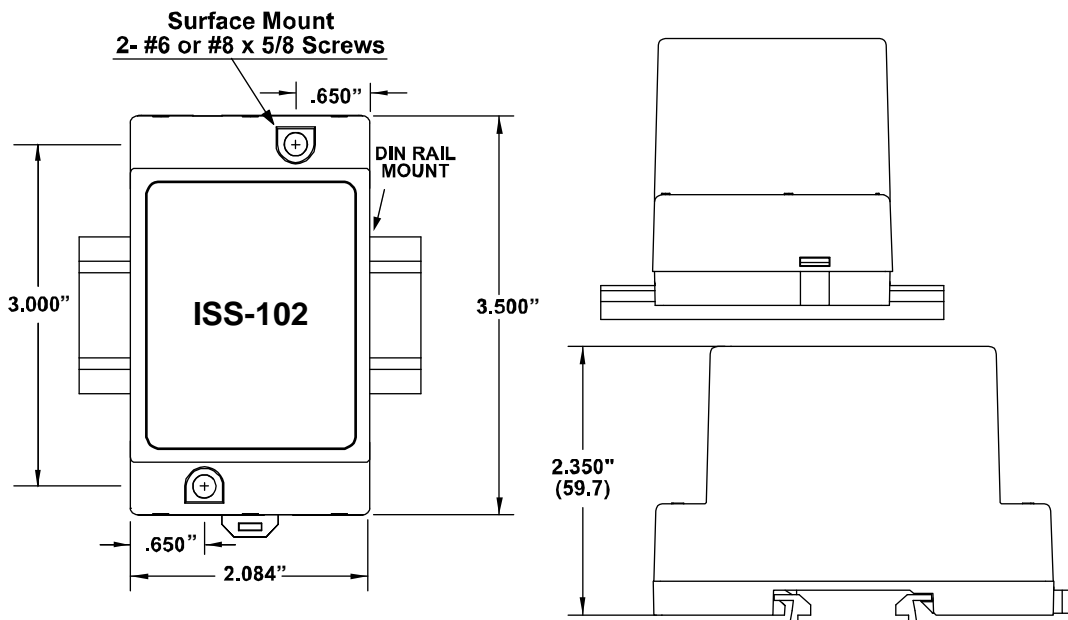

II-ISS-102AADCS-B

# CONTROL DRAWING ISS-102AA

ASSOCIATED APPARATUS / APPAREILLAGE CONNEXE

## Non-Hazardous Location

**Supply Voltage**  
120VAC

**Relay Output Rating**  
5 Amps @ 120VAC General Purpose  
Pilot Duty 180VA @ 120VAC, C150

**Maximum Ambient Temperature Rating**  
55°C

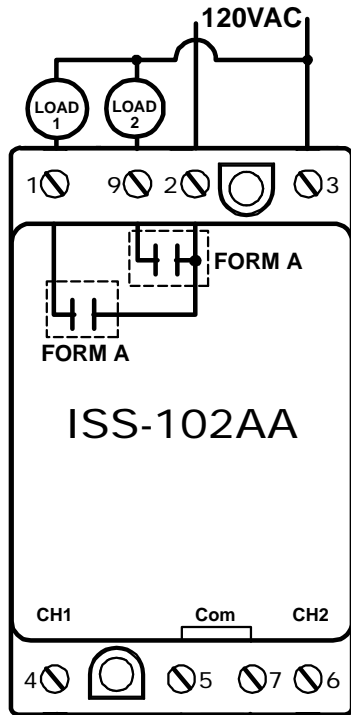

**DEVICE MUST BE INSTALLED IN A SUITABLE ENCLOSURE**

### WARNING!

**TO PREVENT IGNITION OF FLAMMABLE OR COMBUSTABLE ATMOSPHERES, DISCONNECT POWER BEFORE SERVICING.**

**DEVICE MAY ONLY BE REPAIRED BY THE MANUFACTURER**

### WARNING!

**SUBSTITUTION OF COMPONENTS MAY IMPAIR INTRINSIC SAFETY.**

### AVERTISSEMENT!

**LA SUBSTITUTION DE COMPOSANTS PEUT COMPROMETTRE LA SÉCURITÉ INTRINSÈQUE.**

## Hazardous Location

Class I, Divisions I & II, Groups A, B, C & D;  
Class II, Divisions I & II, Groups E, F & G; and  
Class III locations

### NOTES:

1. Maximum distance between unit and switch contact is 10,000 feet.
2. All non-intrinsically-safe wiring shall be separated from intrinsically-safe wiring. Description of special wiring methods can be found in the National Electrical Code ANSI/NFPA 70, Article 504 Intrinsically-Safe Systems. Check your state and local codes for additional requirements.
3. All switch contacts shall be non-energy storing, containing no inductance or capacitance.

### 4. Entity Parameters:

$$\begin{aligned} V_{oc} &= 16.8V & C_a &= 0.39\mu F \\ I_{sc} &= 1.2mA & P_o &= \frac{V_{oc} \cdot I_{sc}}{4} \\ L_a &= 100mH & & \end{aligned}$$

### 5. Entity Parameter Relationships:

<u>IS Equipment</u>		<u>Associated Apparatus</u>
$V_{max}$ (or $U_i$ )	$\geq$	$V_{oc}$ or $V_t$ (or $U_o$ )
$I_{max}$ (or $I_i$ )	$\geq$	$I_{sc}$ or $I_t$ (or $I_o$ )
$P_{max}$ , $P_i$	$\geq$	$P_o$
$C_i + C_{cable}$	$\leq$	$C_a$ (or $C_o$ )
$L_i + L_{cable}$	$\leq$	$L_a$ (or $L_o$ )

Capacitance and inductance of the field wiring from the intrinsically-safe equipment to the associated apparatus shall be calculated and must be included in the system calculations as shown in the table above. Cable capacitance,  $C_{cable}$ , plus intrinsically-safe equipment capacitance,  $C_i$ , must be less than the marked capacitance,  $C_a$  (or  $C_o$ ), shown on any associated apparatus used. The same applies for inductance ( $L_{cable}$ ,  $L_i$  and  $L_a$  or  $L_o$ , respectively). Where the cable capacitance and inductance per foot are not known, the following values shall be used:  $C_{cable} = 60pF/ft.$ ,  $L_{cable} = 0.2\mu H/ft.$