

MOUNTING SPECS:

RECOMMENDED FASTENER: M10 OR 3/8"
TIGHTENING TORQUE (REFERENCE ONLY): 26Nm

REVISION		
REV	DATE	DESCRIPTION
A	2/28/24	527536GCP - RELEASE JTM

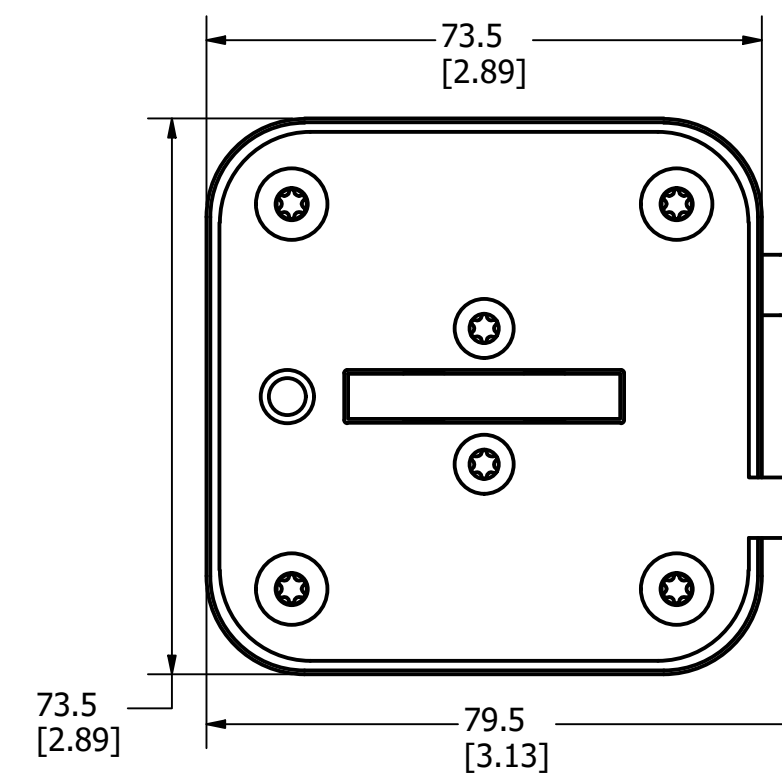
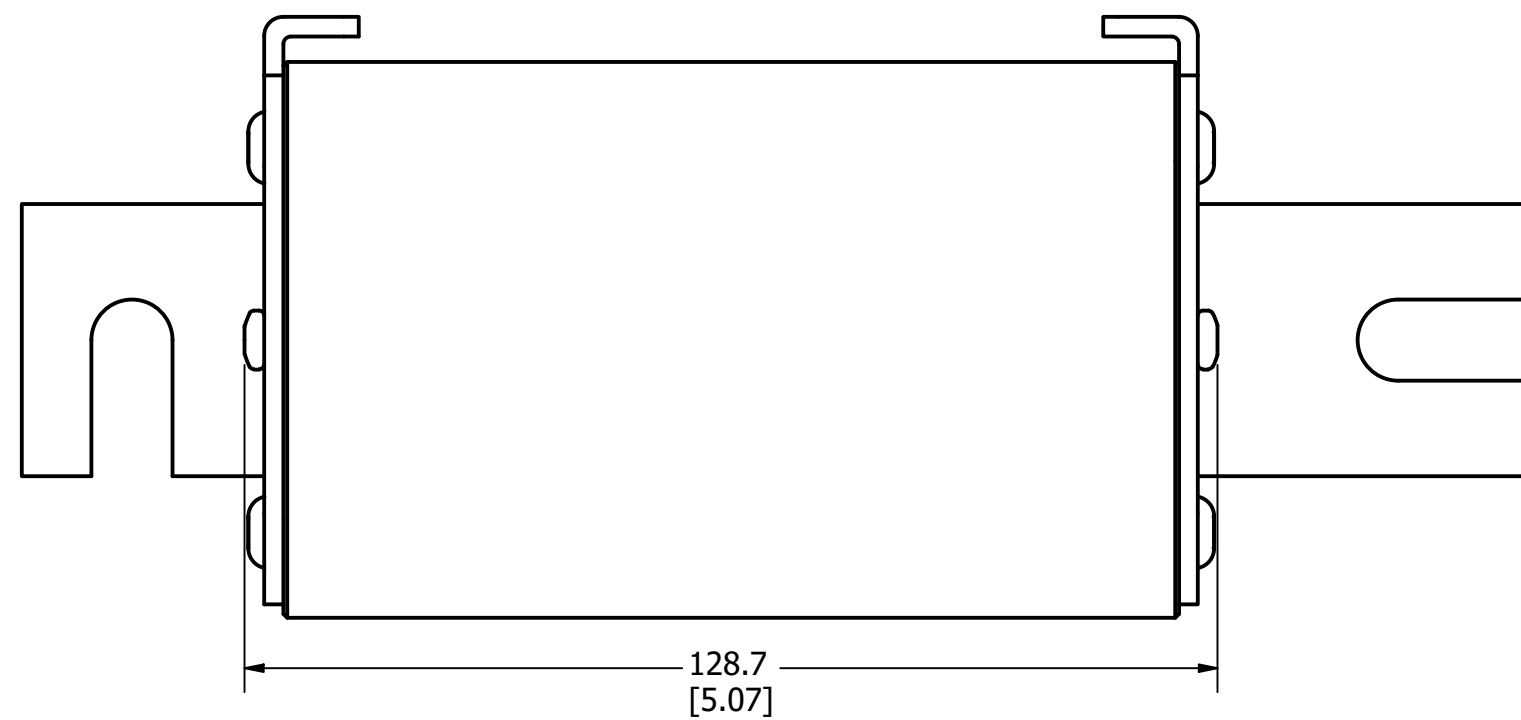
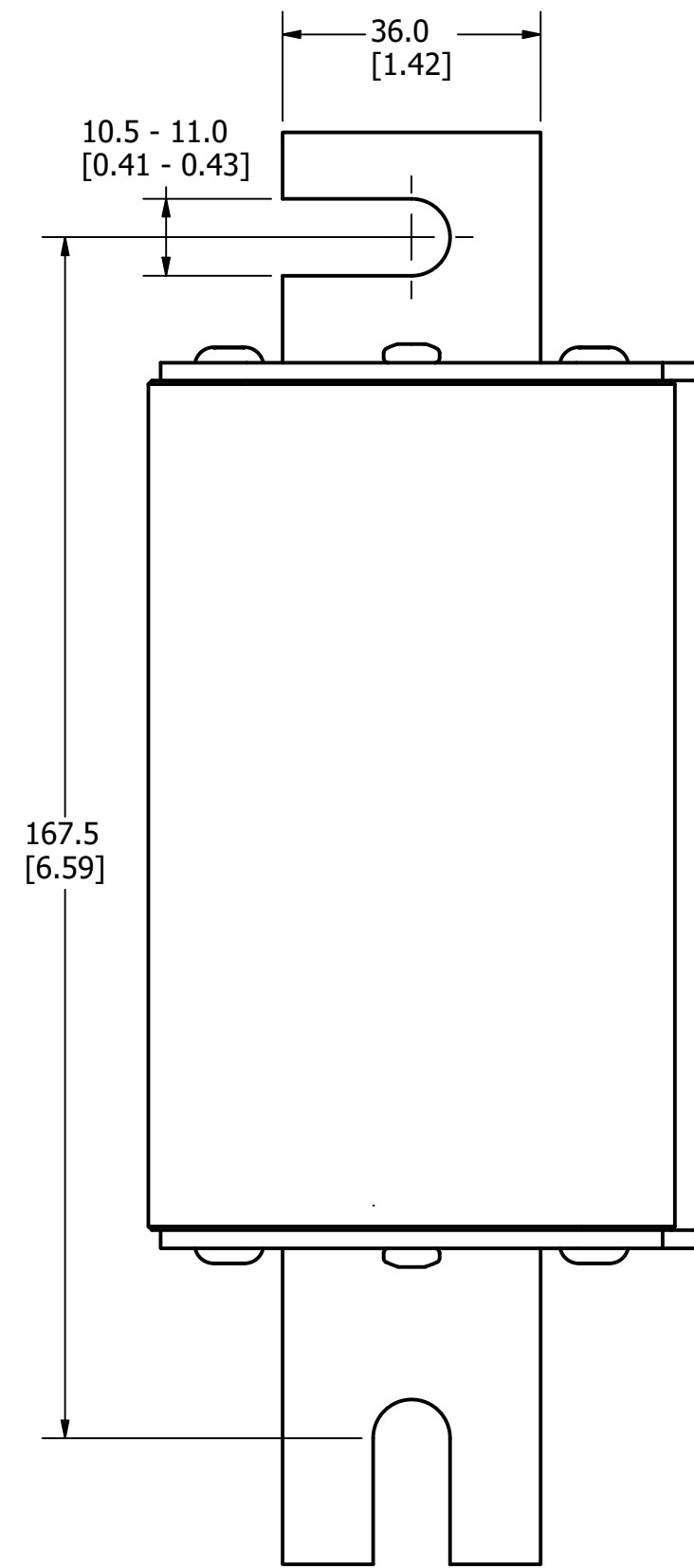
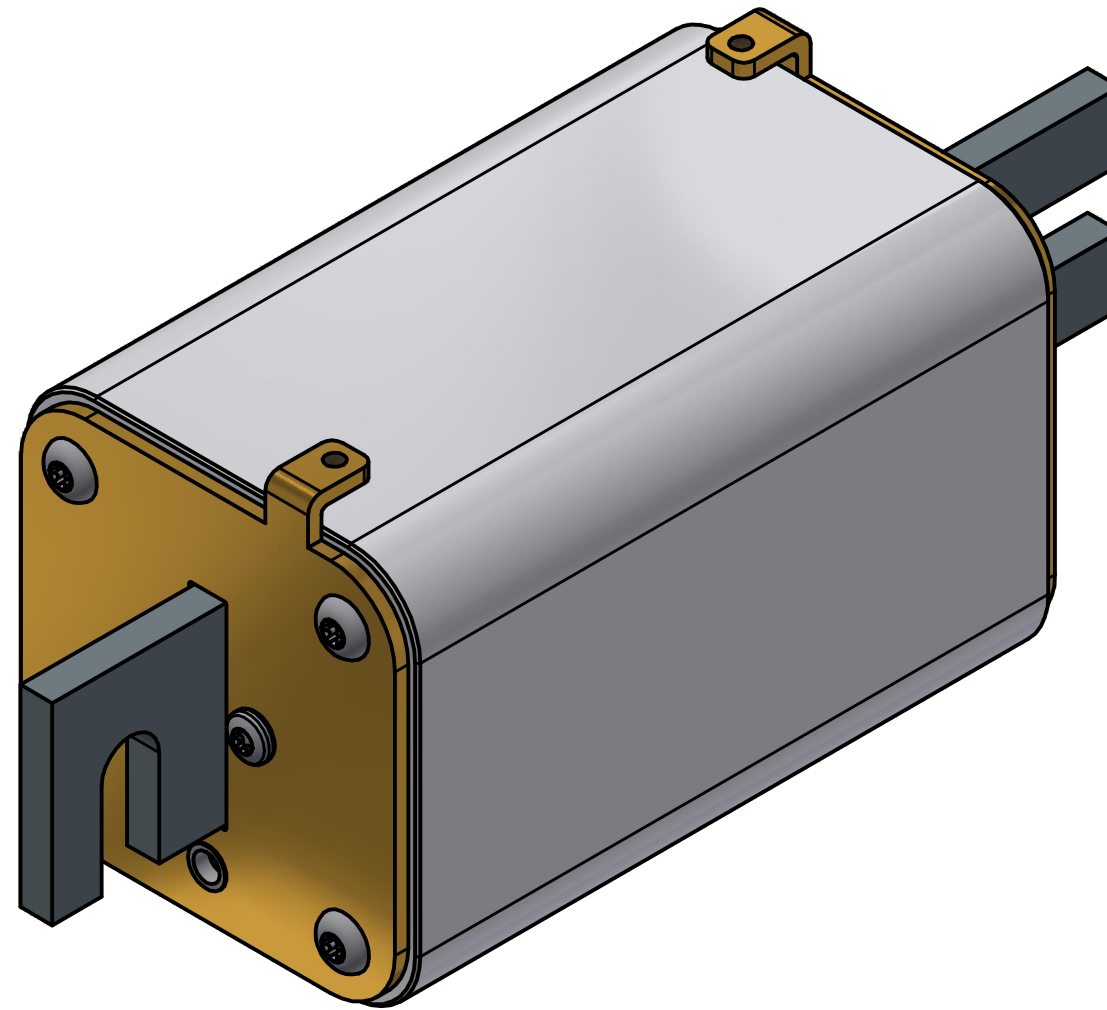
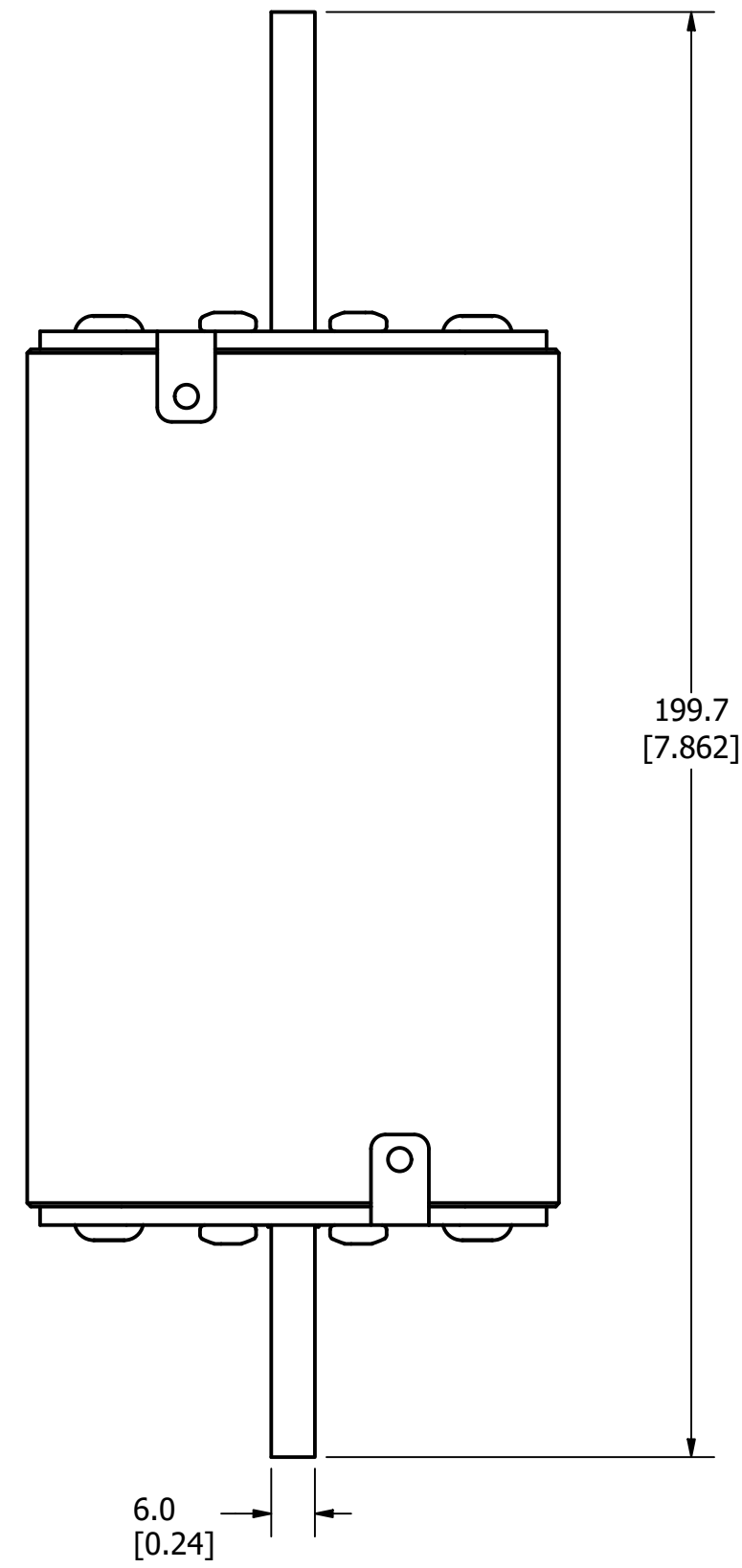

FOR REFERENCE ONLY

<S>	CRITICAL CHARACTERISTIC FOR PART SAFETY/COMPLIANCE
●	DENOTES CRITICAL CHARACTERISTICS.
CPK	DENOTES CPK DIMENSIONS, -MINIMUM CPK VALUE
(ST)	DENOTES A CHARACTERISTIC THAT PROVIDES AN INDICATION OF PROCESS PERFORMANCE. PROCEDURE FOR MEASUREMENT AND TRACKING TO BE DEFINED IN LITTELFUSE INSPECTION INSTRUCTIONS.
CP	DENOTES CP DIMENSIONS, -MINIMUM CP VALUE MUST BE WITHIN THE DIMENSIONAL LIMITATIONS SHOWN ON DRAWING AND INITIALLY LOCATED TO ALLOW FOR MAXIMUM TOOL LIFE.

MATL SPEC	FINISH
DRW JMoler	DATE 12/31/1969
SCALE NTS	FINISH GOOD WT GRAMS/PIECE

UNLESS OTHERWISE SPECIFIED, DIMENSIONS ARE IN MILLIMETERS, DIMENSIONS IN BRACKETS [] ARE INCHES DIMENSIONING AND DO NOT INCLUDE PLATING. TOLERANCING TO BE INTERPRETED IN ACCORDANCE WITH ANSI Y14.5M-1994

3RD ANGLE PROJECTION	
----------------------	--

TITLE ESR SIZE 3XL (DB) FUSE OUTLINE

CHICAGO, ILLINOIS 60631	REVISION A	DRWG NO. OL-ESR3XLDB0000	SHEET 1 OF 1
-------------------------	------------	--------------------------	--------------