

4

3

2

1

NOTE:

1. DYNAMIC TORQUE AT VEHICLE ASSEMBLY PLANT: 5.4Nm±0.9Nm @ 540 RPM MAX

REVISIONS				
ZONE	REV.	DESCRIPTION	DATE	APPROVED
	A	PER EC#514693: INITIAL RELEASE	6/22/2015	J. LIU

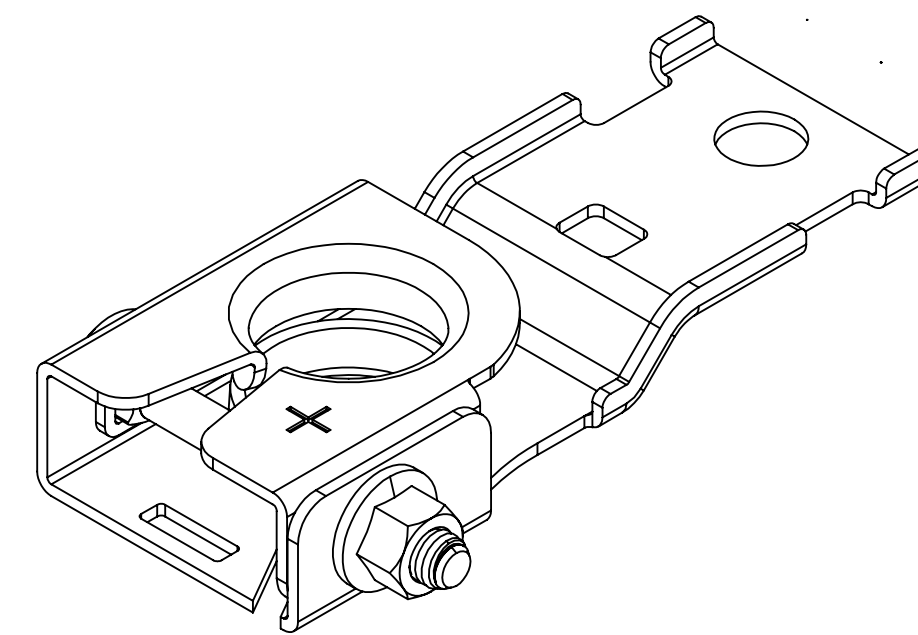
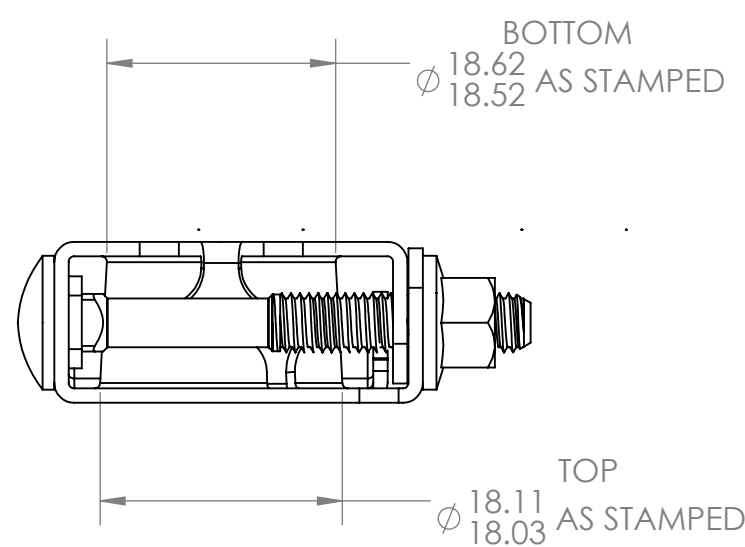
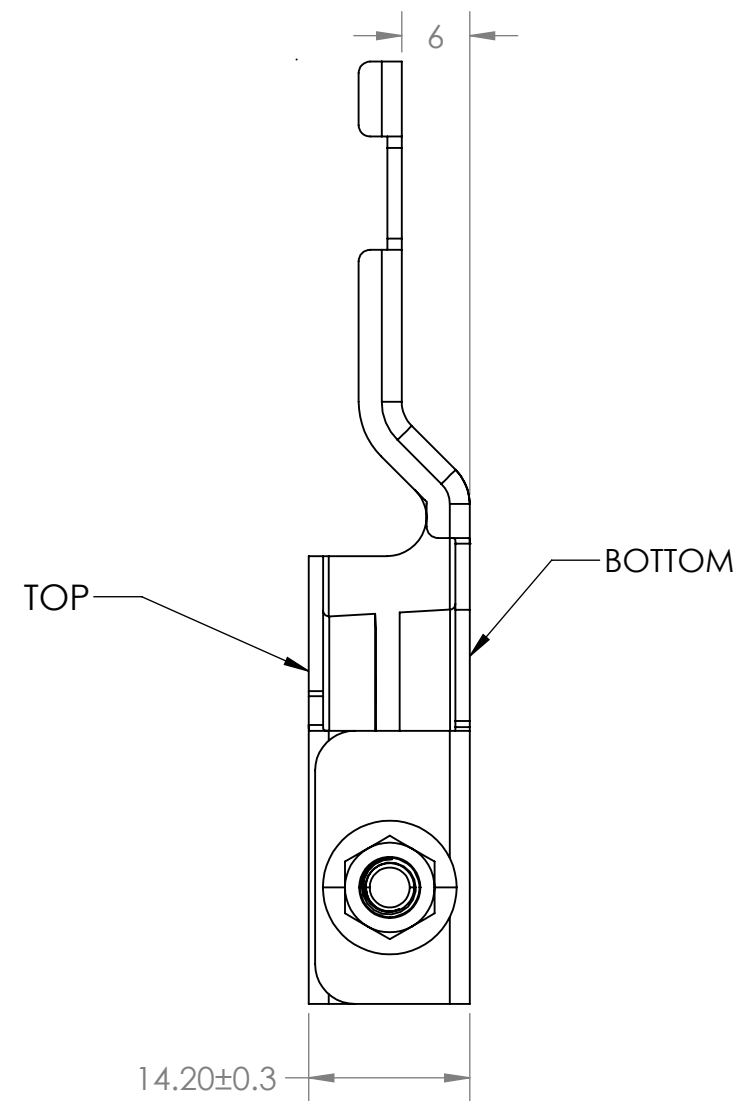
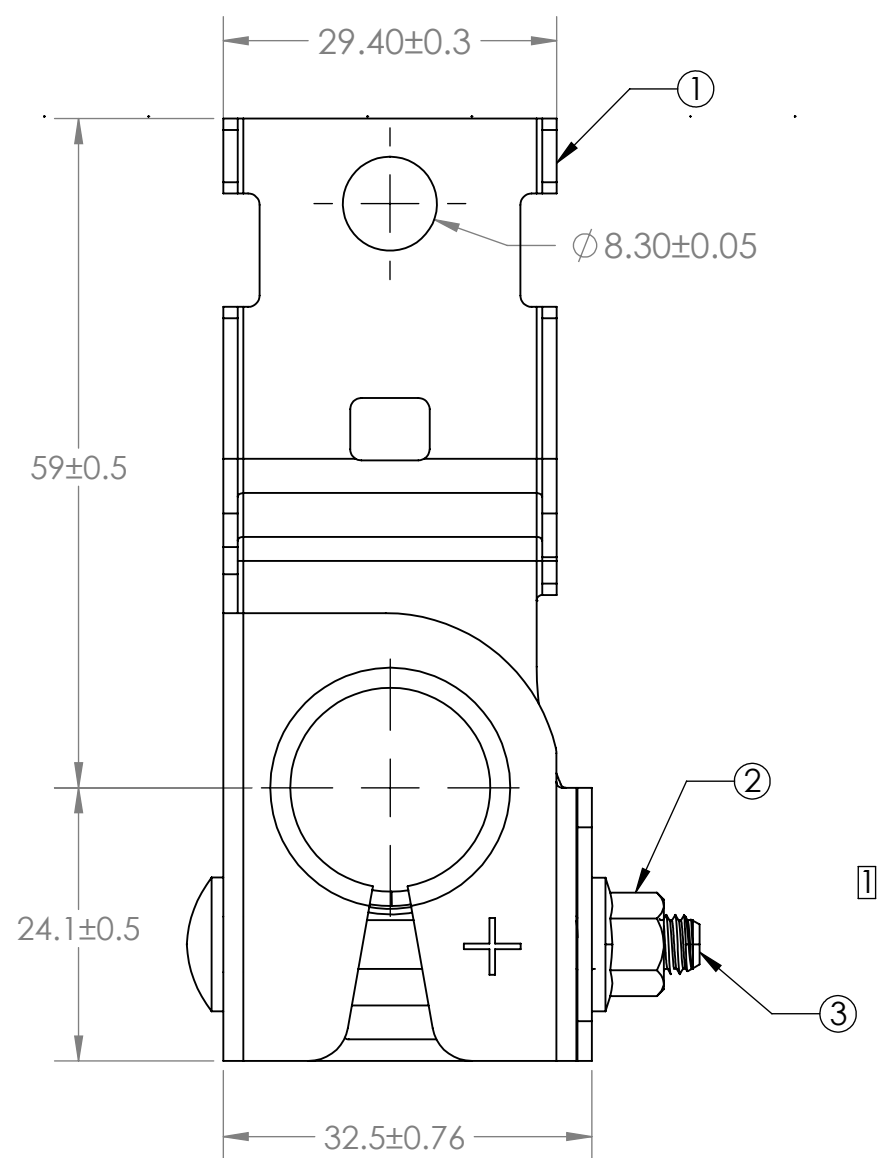

BOM			
ITEM	DESCRIPTION	MATERIAL	QTY
1	BATTERY TERMINAL	ALLOY C194, TIN PLATED WITH MINIMUM THICKNESS OF 0.001	1
2	M6 CARRAGE BOLT		1
3	M6 FLANGE NUT		1

DIMENSIONS ARE IN MM.  
 DIMENSIONS AND TOLERANCES ARE DEFINED ACCORDING TO ANSI / ASME Y14.5M-1994  
 THIS DRAWING AND THE INFORMATION CONTAINED WITHIN IT ARE CONFIDENTIAL AND MAY NOT BE COPIED OR DISCLOSED WITHOUT THE WRITTEN PERMISSION OF LITTELFUSE.

NAME	DATE
DRAWN J. Liu	6/22/2015
CHECKED	



**TERMINAL ASSEMBLY-ZCASE FUSE HOLDER**

SIZE DWG. NO. **876-199** REV. **A**  
 SCALE 1.5:1 SHEET 1 OF 1

4

3

2

1