

7787

MM	IN
0.50	.020
0.76	.030
2.28	.090
4.57	.180
4.82	.190
5.58	.220
8.63	.340
9.14	.360
9.65	.380
10.41	.410
15.24	.600
15.76	.660
18.28	.720
19.55	.770
20.57	.810
21.33	.840
22.09	.870
22.35	.880
22.60	.890
28.44	1.120
35.81	1.410
40.38	1.590
41.91	1.650
44.19	1.740
45.95	1.760

COLE-HERSEE CO.
NPM 6-8-77

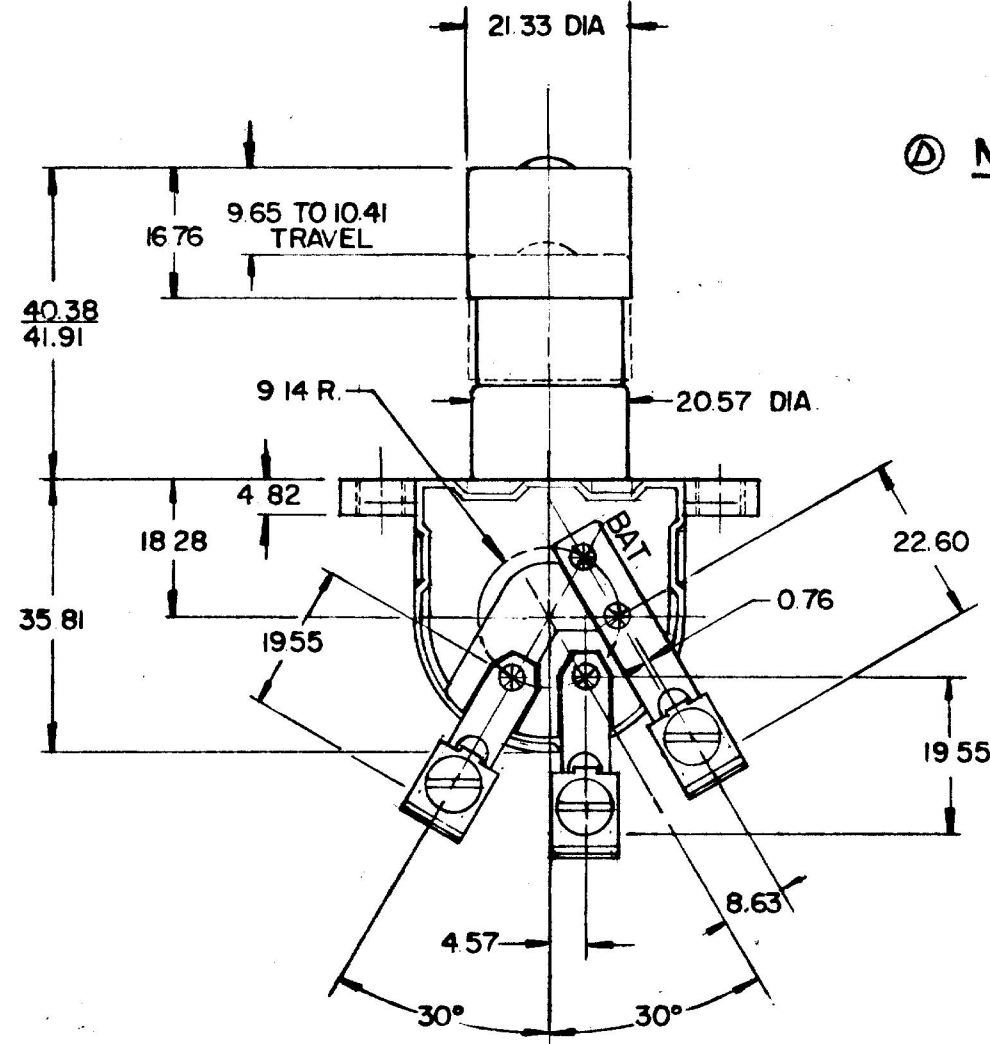
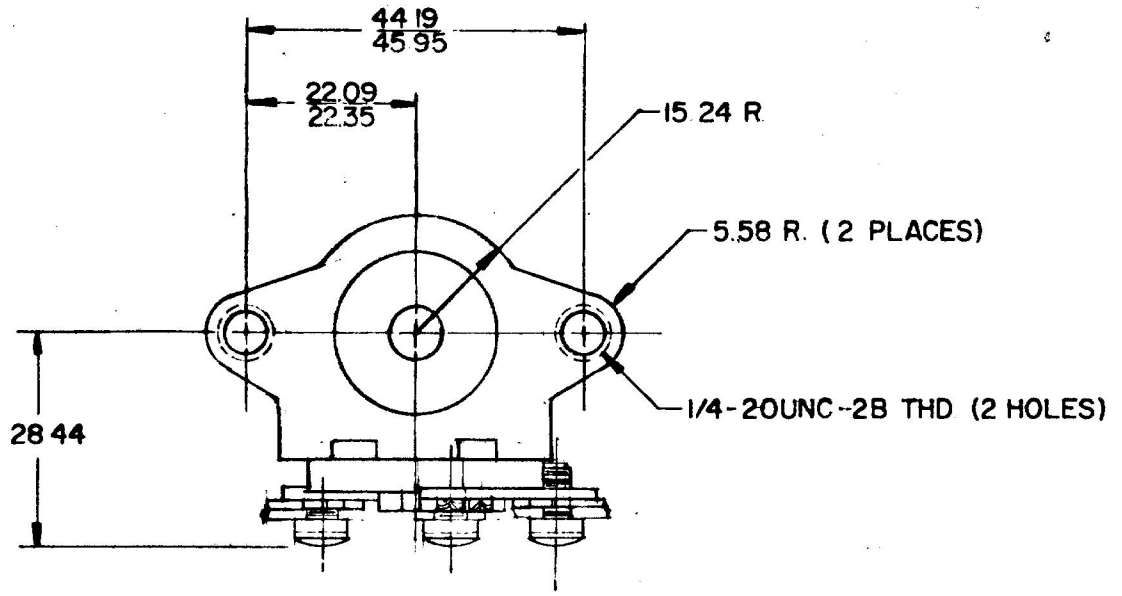

NOTE:
 TERMINAL SCREWS TO BE ASSEMBLED WITH CLEARANCE FOR TERMINAL L'WASHER ASSEMBLY. SCREWS TO BE TIGHT TO PREVENT CHANGING POSITION IN SHIPMENT.

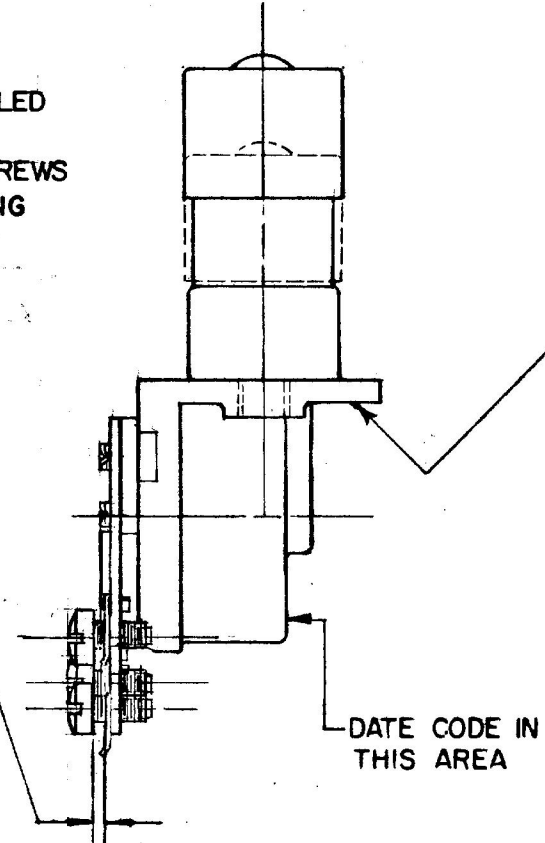

BASE, ZINC DIE CAST, DICHROMATED
 TERMINALS, STEEL, ZINC PLATED
 BUTTON, STEEL, ZINC PLATED
 CONTACT, COPPER CADMIUM
 BACK, MOLDING MATERIAL

DO NOT SCALE

METRIC

LET	WAS	DATE	BY	LET	WAS	DATE	BY	MATERIAL	DRAWN	CHECKED	APPR'D.	SCALE	DATE DRAWN
								#	RMT	3-30-78		FULL	3-15-77
								#	COLE-HERSEE COMPANY				DATE BLUEPRINT
									BOSTON, MASS. 02127, U.S.A.				
				D	REVISED NOTE	21338	3-4-81		TOLERANCES				7787
				C	CHANGE IN MATERIAL		4-3-78		FRACTIONAL ±				
				B	REWORK		3-30-78		DECIMAL ± .02				