

SE-125 MANUAL

GROUND-FAULT GROUND-CHECK MONITOR

FEBRUARY 14, 2001

REVISION 3

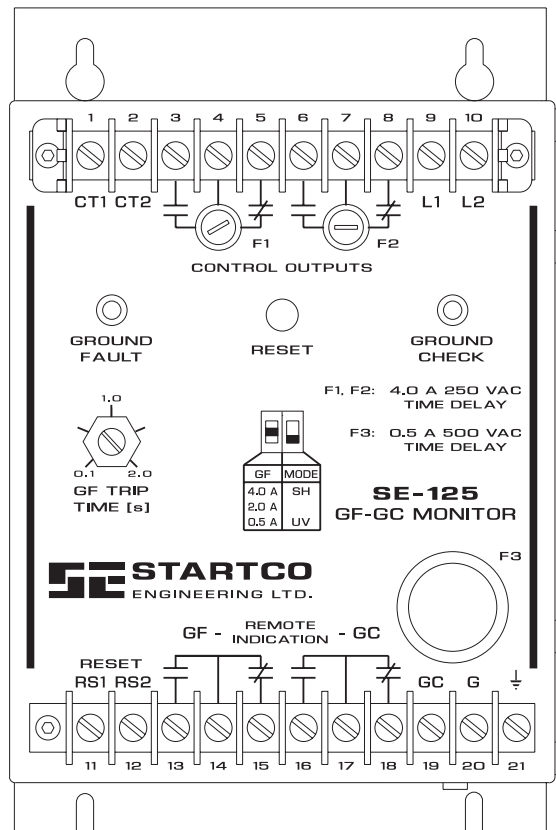

Copyright © 2001 by Startco Engineering Ltd.

All rights reserved.

Blank Page



TABLE OF CONTENTS

	PAGE
Table of Contents	i
List of Figures	i
1. General	1
2. Operation.....	1
2.1 Settings.....	1
2.1.1 GF Trip Time	1
2.1.2 GF	1
2.1.3 Mode.....	1
2.2 Indication and Reset	1
2.3 Fusing.....	1
3. Installation.....	1
3.1 Ground Fault.....	1
3.2 Ground Check.....	1
3.3 Supply Voltage	3
3.4 Parallel-Path Isolation	3
4. Technical Specifications.....	3
5. Ordering Information	3

LIST OF FIGURES

FIGURE		PAGE
1	Typical Application.....	2
2	SE-125 Outline.....	4
3	SE-TA12A Termination	5
4	Current Transformers.....	6
5	PPI-600V Parallel-Path Isolator	7
6	PPI-600V Typical Application	8

DISCLAIMER

Specifications are subject to change without notice. Startco Engineering Ltd. is not liable for contingent or consequential damages, or for expenses sustained as a result of incorrect application, incorrect adjustment, or a malfunction.

Blank Page



1. GENERAL

The SE-125 is a combination ground-fault and high-output, ground-check monitor for non-hazardous, resistance-grounded installations. The high-output, ground-check circuit is suitable for slip-ring or commutated-load applications. Two Form C output contacts are provided for contactor control, or for shunt or undervoltage operation in a breaker trip circuit. Two Form C contacts are provided for remote indication.

Ground-fault current is sensed by a CT200 series window-type current transformer with a 5-A secondary. A trip level of 0.5 A, 2.0 A, or 4.0 A is switch selectable for use with a 5-A, 15-A, or 25-A grounding resistor. This corresponds to 0.25%, 1.0%, or 2.0% of the primary rating of the current transformer. Trip time is adjustable from 0.1 to 2.0 seconds.

The SE-125 ground-check circuit recognizes the SE-TA12A's 12-volt Zener characteristic as a valid end-of-line completion. This is the only passive characteristic that will satisfy the ground-check circuit's multi-level drive, allow induced currents to circulate in the ground-check loop, survive a phase-to-ground-check fault, and clamp the ground-check voltage during the fault.

2. OPERATION

2.1 SETTINGS

2.1.1 GF TRIP TIME

Ground-fault trip time is adjustable from 0.1 to 2.0 seconds. Time-coordinated ground-fault protection requires this setting to be longer than the trip time of downstream ground-fault devices.

2.1.2 GF

The ground-fault-circuit trip level is 0.5 A, 2.0 A, or 4.0 A when current is sensed with a CT200 series current transformer. Since the ground-fault-circuit trip level should be less than 1/5 of the grounding resistor let-through current, these levels are appropriate for use with 5-A, 15-A, or 25-A grounding resistors. For other applications the trip level of the ground-fault circuit is 0.25%, 1.0%, or 2.0% of the primary rating of the 5-A secondary current transformer.

2.1.3 MODE

In the shunt-trip mode (SH), the control output relay energizes and its normally open contacts close if the ground-check loop is not valid or if a ground-fault trip occurs. The shunt-trip mode is not fail-safe and is not recommended because:

- Shunt-trip devices do not operate if supply voltage fails.
- Shunt-trip ground-check circuits allow open cable couplers to be energized for a short interval after supply voltage is applied.

In the undervoltage mode (UV), the control output relay energizes when the ground-check loop is valid and the ground-fault circuit is not tripped. The undervoltage mode is referred to as fail-safe and is recommended because:

- Undervoltage devices release if control voltage fails.
- Undervoltage ground-check circuits do not allow cable couplers to be energized until the ground-check loop is verified.

2.2 INDICATION AND RESET

The red LED indicates a ground-fault trip and the green LED indicates a valid ground-check loop. When a ground-fault trip occurs, the SE-125 remains latched until the reset switch is pressed, a reset voltage is applied, or the supply voltage is cycled. The ground-check circuit is non-latching and does not require a reset.

Relays GF and GC provide remote-indication of ground-fault and ground-check status. Relay GF energizes when a ground-fault trip occurs and relay GC energizes when the ground-check loop is valid. Remote-indication relays are not for use in control circuits.

2.3 FUSING

The control output contacts are protected by 4.0-A, time-delay fuses (F1 & F2). The ground-check circuit is protected by a 0.5-A, time-delay fuse (F3).

3. INSTALLATION

3.1 GROUND FAULT

Pass the phase conductors through the CT window as shown in Fig. 1. Do not pass the ground or ground-check conductors through the CT. In applications that require shields or drain wires to pass through the CT, return them through the CT before connecting them to ground.

Connect the secondary of the ground-fault CT to terminals **CT1** and **CT2** on the SE-125. Ground one side of the CT secondary.

3.2 GROUND CHECK

Install an SE-TA12A Termination Assembly at the load to complete the ground-check loop as shown in Fig. 1. Low-level (bifurcated, precious-metal, or sealed-reed) contacts are recommended if ground-check interlocks are used. Connect terminal **G** of the termination device to the equipment frame so that the ground-conductor-to-equipment-frame connection will be included in the monitored ground-check loop. Connect terminal **G** of the SE-125 to ground. Do not jumper chassis-bonding terminal (\perp) to terminal **G**.

If the SE-125 is used in a ground-fault-only application, an SE-TA12A must be connected to the ground-check and cable-ground terminals to validate the ground-check circuit.

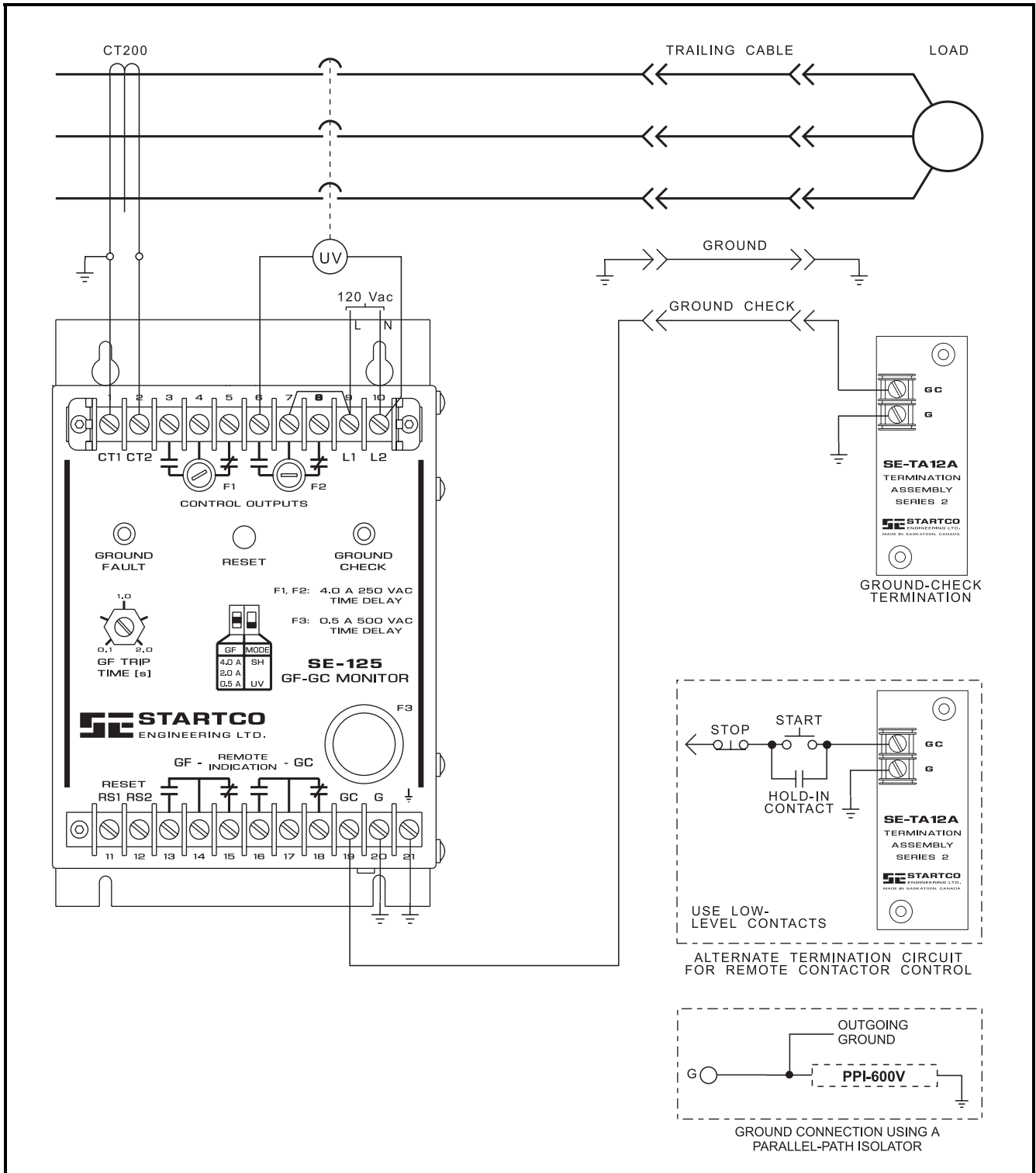

FIGURE 1. Typical Application.



3.3 SUPPLY VOLTAGE

Connect supply voltage to **L1** and **L2** as shown In Fig. 1. In 120-Vac systems, **L2** is usually designated as the neutral conductor.

3.4 PARALLEL-PATH ISOLATION

A PPI-600V can be used for parallel-path rejection. A PPI-600V will also eliminate intermachine arcing and prevent stray ac and dc currents from flowing in the monitored ground wire. See Figs. 5 and 6. Contact Startco for application details.

4. TECHNICAL SPECIFICATIONS

Supply:

120 or 240 Vac (+10%, -40%), 50/60 Hz, 20 VA

Dimensions:

Height 216 mm (8.5")
Width 146 mm (5.8")
Depth 104 mm (4.1")

Environment:

Operating Temperature -40°C to 60°C
Storage Temperature -55°C to 80°C

Ground-Fault Circuit:

CT Ratio 200:5
CT Burden 0.02 Ω
Trip Level * 0.5 A, 2.0 A, or 4.0 A
Trip Time 0.1 s to 2.0 s Adjustable
Thermal Withstand * 200 A Continuous
2500 A for 2 seconds
Trip-Level Accuracy +10%, -20%
Trip-Time Accuracy ± 10%
Operating Mode Latching

* Currents referred to primary of 200:5 CT for prospective ground-fault currents less than 4000 A.

Ground-Check Circuit:

Open-Circuit Voltage 24 Vdc
Output Impedance 88 Ω
Nominal Operating Current 125 mA
Induced AC Withstand 25 Vac Continuous
120 Vac for 5 seconds
Fuse Rating (F3) 0.5 A, 500 Vac,
Time Delay
Fuse Part Number Bussman FNQ-1/2

Pull-in Time 1.5 seconds
Trip Time 0.2 s (GC or G open)
0.5 s (GC to G short)
Trip-Time Accuracy +10%, -30%
GC-Loop Trip Resistance 25 ± 3 Ω
Operating Mode Non-Latching

Control Output Relay:

Contact Rating 1 mA to 4 A Resistive,
240 Vac or 28 Vdc.
Contact Configuration 2 Form C
Fuse Rating (F1 and F2) 4.0 A, 250 Vac,
Time Delay
Fuse Part Number Bussman MSL-4 or
Littelfuse 313.004
Operating Mode UV (Undervoltage/Fail-
Safe) or SH (Shunt
Trip/Non-Fail-Safe)

Remote Indication Relays:

Contact Rating 1 mA to 500 mA
Resistive,
120 Vac or 28 Vdc
Contact Configuration Form C

Isolated Remote Reset:

Reset Voltage 24 Vac/Vdc to
120 Vac/Vdc
Input Resistance 8.2 kΩ
Isolation Voltage 300 Vac Continuous

NOTE: Voltage between supply terminals (L1, L2) and ground terminal (G) must not exceed 300 Vac continuous or 1250 Vac under transient conditions.

5. ORDERING INFORMATION

SE-125 120-Vac Supply Ground-Fault
Ground-Check Monitor
SE-125E 240-Vac Supply Ground-Fault
Ground-Check Monitor
SE-TA12A 12-V Termination Assembly
200:5 Ground-Fault CT's:
CT200 56 mm (2.2") Window
CT200L 89 mm (3.5") Window
PPI-600V Parallel-Path Isolator

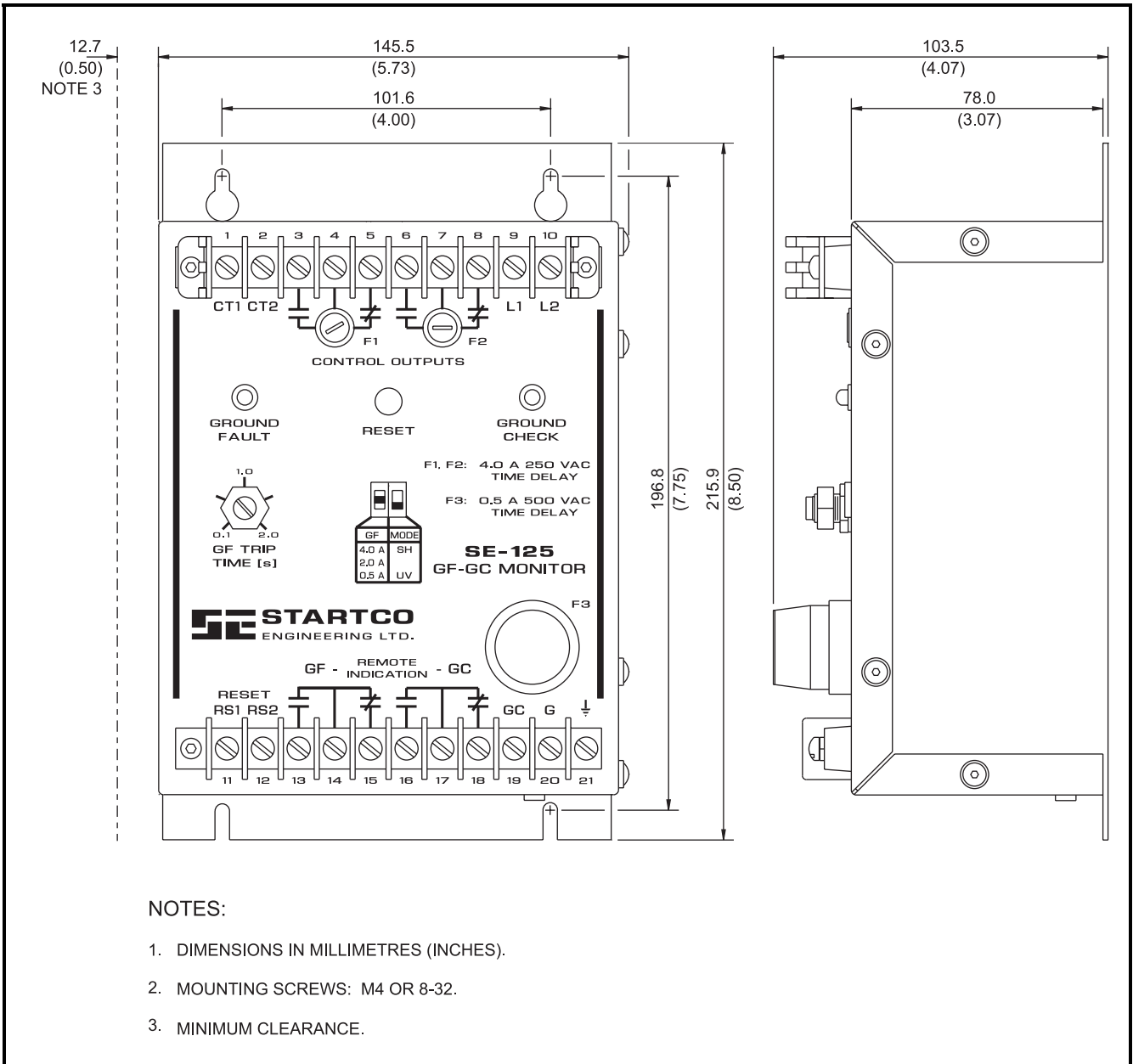
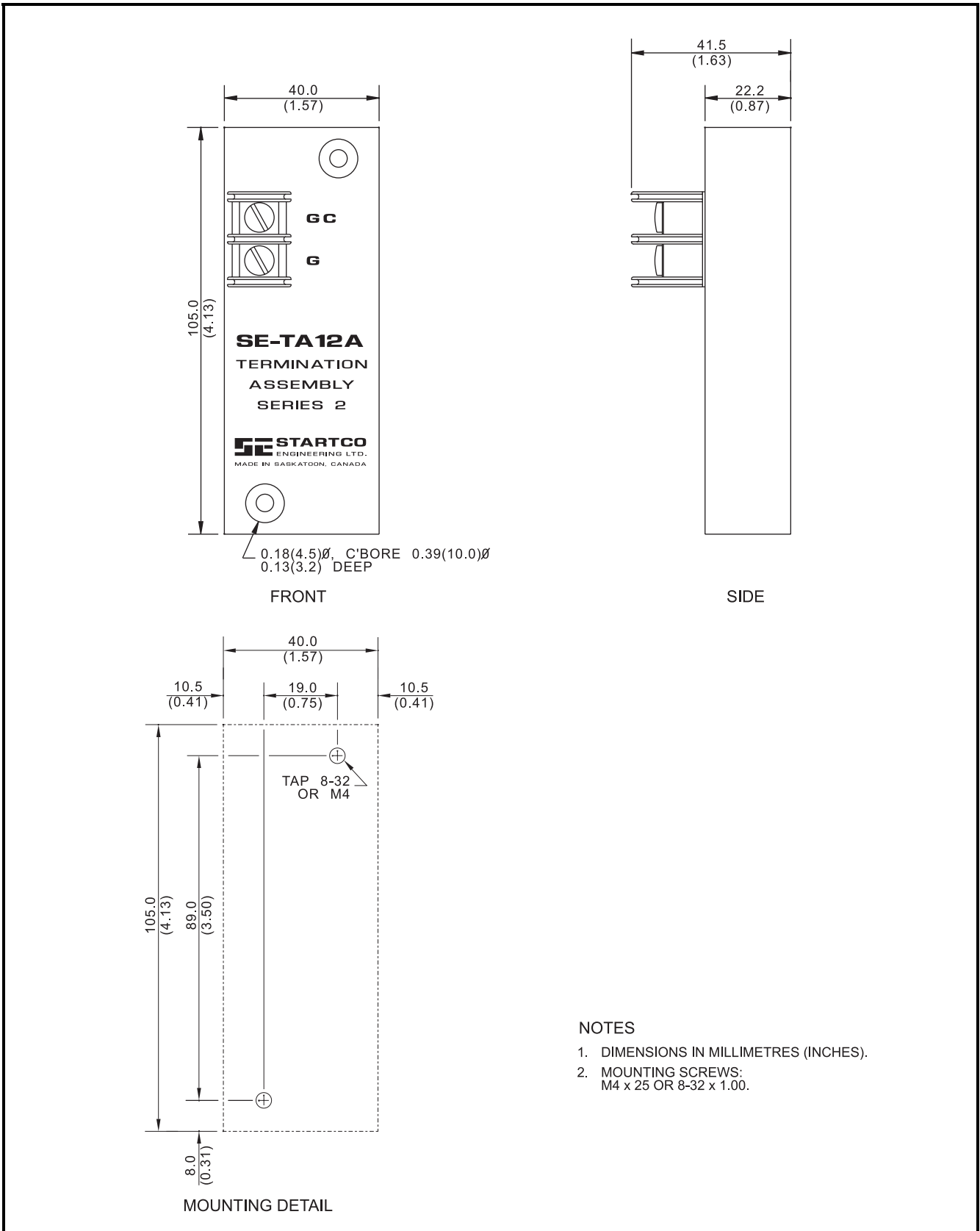

FIGURE 2. SE-125 Outline.



NOTES

1. DIMENSIONS IN MILLIMETRES (INCHES).
2. MOUNTING SCREWS:
M4 x 25 OR 8-32 x 1.00.

FIGURE 3. SE-TA12A Termination.

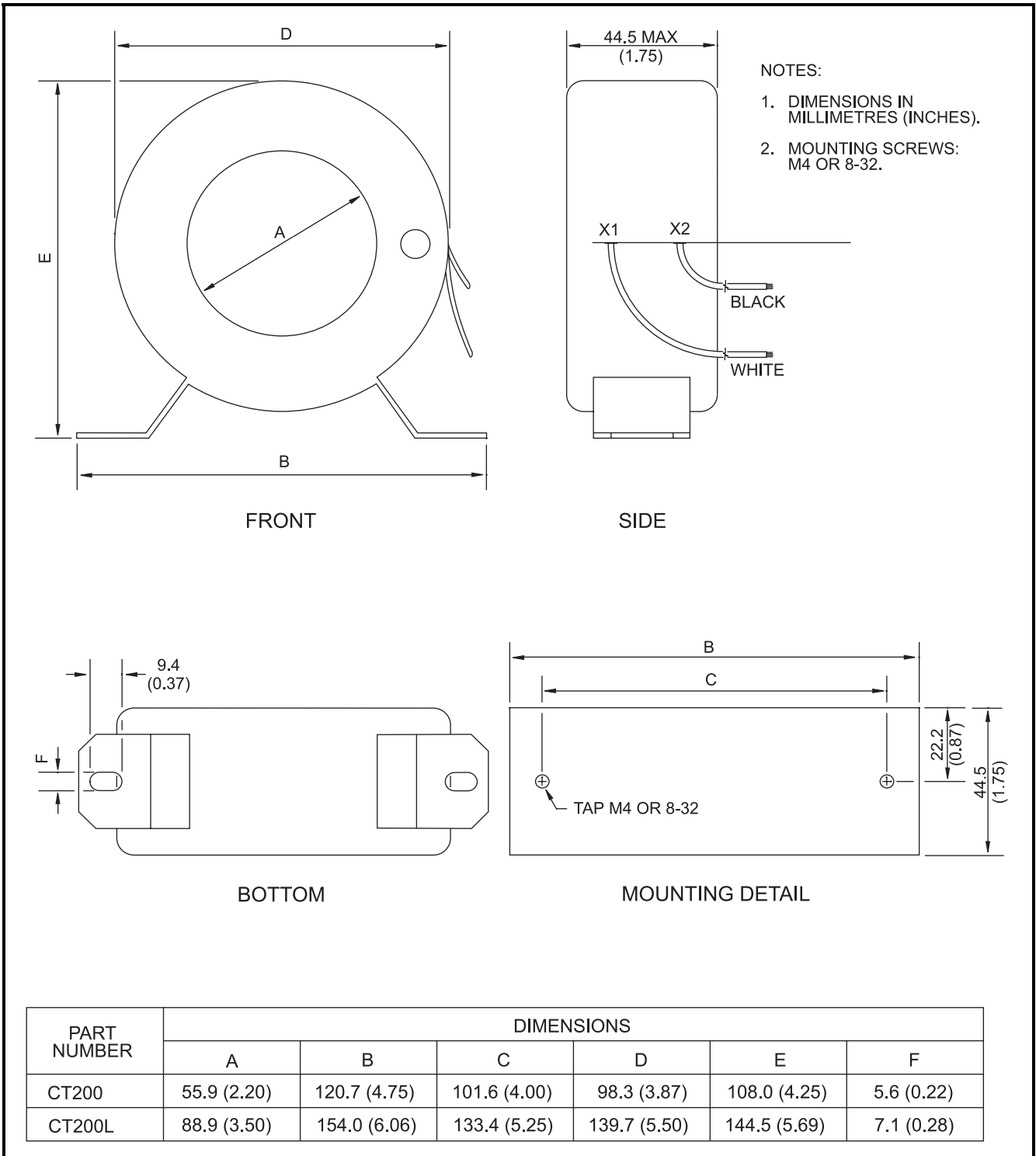

FIGURE 4. Current Transformers.

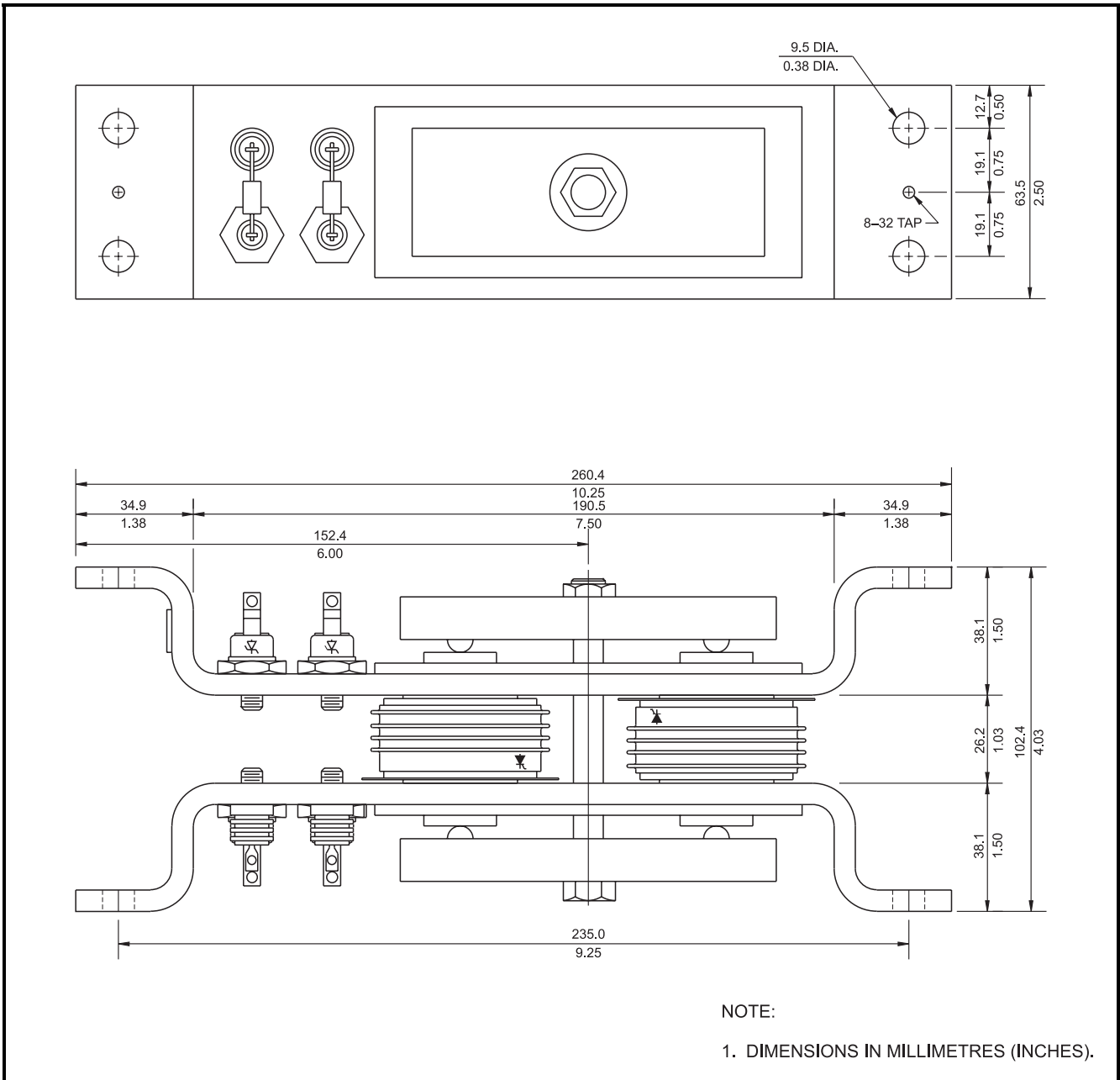

FIGURE 5. PPI-600V Parallel-Path Isolator.

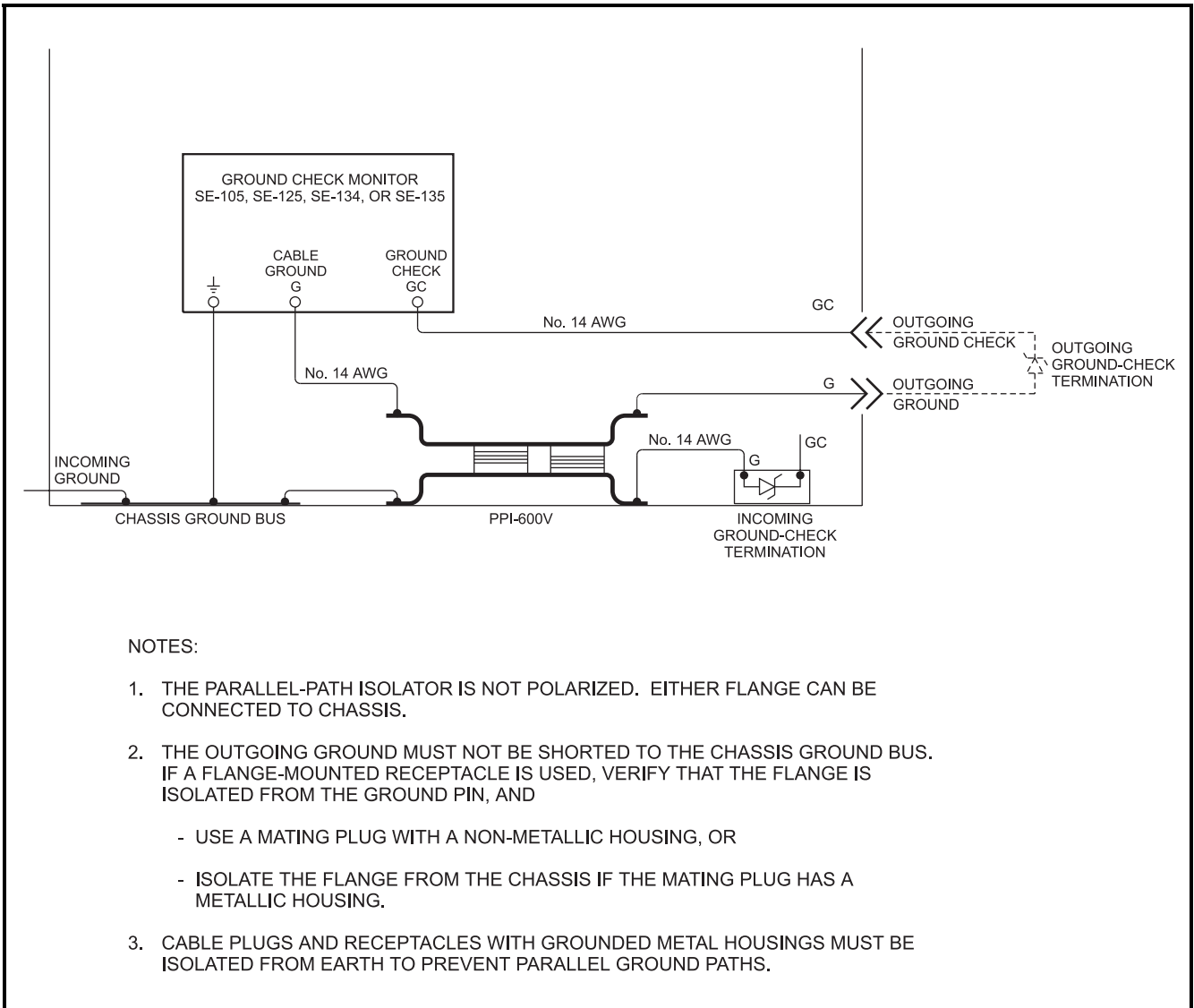

FIGURE 6. PPI-600V Typical Installation.