

**BPU-2A MANUAL**  
**BEARING PROTECTION UNIT**

MARCH 1994

REVISION 2

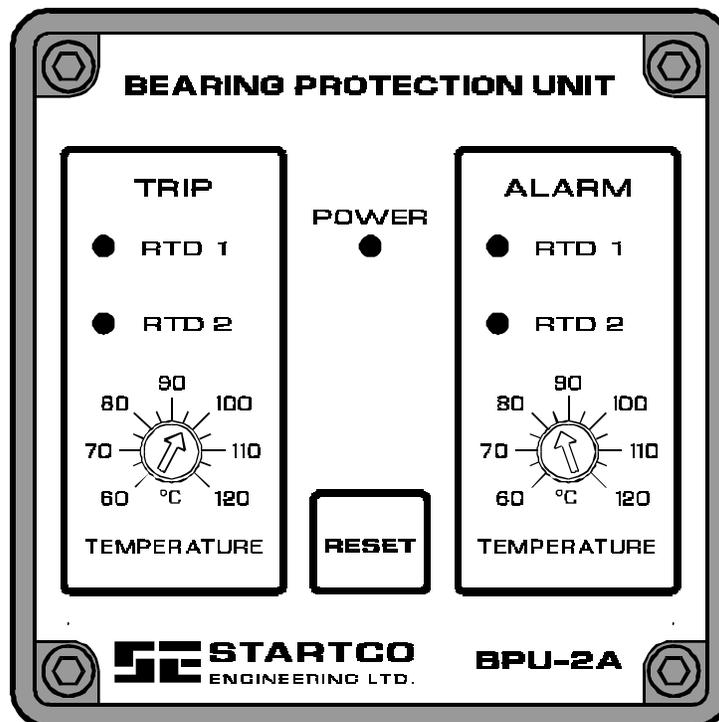

Copyright © 1994 by Startco Engineering Ltd.

All rights reserved.

## **DISCLAIMER**

This document has been downloaded from the Internet and might not be complete—document quality and formatting depend on the user's computer. This Internet manual is intended as a temporary guide—obtain an original document from Startco or from an authorized Startco distributor.

Specifications are subject to change without notice. Startco Engineering Ltd. is not liable for contingent or consequential damages, or for expenses sustained as a result of a malfunction, incorrect application, or incorrect adjustment.

## TABLE OF CONTENTS

	<b>PAGE</b>
TABLE OF CONTENTS .....	i
LIST OF FIGURES .....	i
1. GENERAL.....	1
2. OPERATION .....	1
2.1 TRIP-AND-ALARM SET POINTS.....	2
2.2 INDICATION AND RESET.....	2
2.3 CONFIGURATION .....	2
2.3.1 RELAY OPERATION (S1-1) .....	2
2.3.2 TRIP DIFFERENTIAL (S1-2, S1-3) .....	3
2.3.3 ALARM DIFFERENTIAL (S1-4).....	3
2.3.4 BEARING RTD's (S1-5, S1-6) .....	3
2.3.5 MPU-16A SENSOR TYPE (S1-7, S1-8) .....	3
2.3.6 MPU-16A/STAND ALONE (W1).....	3
2.3.7 LATCHING/NON LATCHING (W2).....	3
2.4 BPU-2A/MPU-16A OPERATION WITHOUT A STATOR RTD .....	4
3. INSTALLATION .....	4
3.1 PANEL-MOUNT CONFIGURATION .....	4
3.2 SURFACE-MOUNT CONFIGURATION .....	4
3.3 TERMINAL BLOCKS .....	4
3.4 RTD CONNECTIONS .....	5
3.5 POWER SUPPLY.....	5
4. TECHNICAL SPECIFICATIONS .....	5
5. ORDERING INFORMATION .....	6

## LIST OF FIGURES

<b>FIGURE</b>	<b>PAGE</b>
1 BPU-2A TYPICAL APPLICATION.....	7
2 BPU-2A CONFIGURATION.....	8
3 PANEL-MOUNT BPU-2A OUTLINE AND MOUNTING DETAILS.....	9
4 SURFACE-MOUNT BPU-2A OUTLINE AND MOUNTING DETAILS.....	10

## **BPU-2A BEARING PROTECTION UNIT**

### **1. GENERAL**

The BPU-2A is a microprocessor-based bearing protection unit. Trip-and-alarm set points and LED indication are provided for two bearing RTD's. The BPU-2A can be user configured for 100-ohm platinum (PT100), 100-ohm nickel (NI100), or 120-ohm nickel (NI120) RTD's. The BPU-2A can trip-and-alarm on bearing temperature and on the temperature differential between two bearings.

The BPU-2A was designed to add bearing-temperature protection to the MPU-16A motor protection unit; however, it can be used as a stand-alone unit to monitor two bearing RTD's. In the stand-alone configuration, two Form A output contacts can be user configured for fail-safe or non-fail-safe operation.

### **2. OPERATION**

When used with the MPU-16A, the BPU-2A accepts inputs from two bearing RTD's and one stator RTD as shown in Figure 1. The stator temperature signal is fed to the MPU-16A through the BPU-2A relay contacts and external jumper W1. If the bearing alarm temperature is exceeded, the stator signal is interrupted and 4AA0 is displayed on the MPU-16A. If the bearing trip temperature is exceeded, the BPU-2A introduces a trip resistance and 4FFF is displayed on the MPU-16A. When a bearing temperature trip or alarm occurs, MPU-16A hot-motor compensation is automatically disabled, MPU-16A pre-trip stator temperatures are not available, and bearing temperatures can be determined with the BPU-2A. A bearing temperature trip can be differentiated from a stator temperature trip by observing the pre-trip value in Mode C. If a bearing temperature trip occurs, the pre-trip value will be between 230°C and 240°C. If a stator temperature trip occurs, the pre-trip value will be equal to the temperature set point (Mode 4).

When used with the MPU-16A, jumper W1 must be installed between terminals 10 and 11 and the trip-and-alarm contacts cannot be used in external circuits. For stand-alone operation, jumper W1 must be removed so that the trip-and-alarm contacts can be used.

#### **--- CAUTION ---**

IN STAND-ALONE OPERATION, MAKE NO CONNECTIONS TO TERMINALS 7, 8, 9, 17, 18, and 19.

## 2.1 TRIP-AND-ALARM SET POINTS

Bearing temperature trip-and-alarm set points are adjustable from 60°C to 120°C. Typical set points are 70°C to 100°C for anti-friction bearings and 60°C to 75°C for journal bearings. Consult the motor manufacturer for recommended set points.

For differential temperature trip-and-alarm settings, see sections 2.3.2 and 2.3.3.

## 2.2 INDICATION AND RESET

Two red LED's indicate over-temperature trips and two yellow LED's indicate over-temperature alarms. A slowly flashing LED indicates the hottest RTD when a differential temperature trip-or-alarm occurs. A quickly flashing yellow LED indicates an open or shorted RTD.

Alarms are non-latching and trips can be selected as latching or non-latching. Install jumper W2 between terminals 5 and 6 for non-latching operation. With jumper W2 not installed, trips remain latched until RESET is pressed or until supply voltage is cycled.

When used with the MPU-16A, non-latching operation is usually selected so that only the MPU-16A requires a reset after a bearing-temperature trip.

## 2.3 CONFIGURATION

The rear panel must be removed to access configuration switch S1. Configuration jumpers W1 and W2 are external jumpers on the lower terminal block.

### 2.3.1 RELAY OPERATION (S1-1)

Switch S1-1 configures the BPU-2A for fail-safe or non-fail-safe relay operation. See Figure 2. In the fail-safe mode, output relays are energized when control power is on and the BPU-2A is not in a trip-or-alarm condition. The output relays are de-energized if control power is off or if a trip-or-alarm occurs. BPU-2A labelling shows the relays de-energized. In the non-fail-safe mode, output relays are energized only during a trip-or-alarm.

When used with MPU-16A, select the fail-safe mode.

Factory Selection ..... Fail Safe

### **2.3.2 TRIP DIFFERENTIAL (S1-2, S1-3)**

Switches S1-2 and S1-3 set the BPU-2A trip differential. Selections available are: Disabled, 10°, 15°, or 20°. See Figure 2.

Factory Selection ..... Disabled

### **2.3.3 ALARM DIFFERENTIAL (S1-4)**

Switch S1-4 sets the alarm differential if the trip differential is enabled. Selections available are: 50% or 80% of the trip differential. See Figure 2.

Factory Selection ..... 50% of Trip Differential

### **2.3.4 BEARING RTD's (S1-5, S1-6)**

Switches S1-5 and S1-6 configure the BPU-2A for the bearing-RTD type. Selections available are: 100-ohm platinum (PT100), 100-ohm nickel (NI100), or 120-ohm nickel (NI120). See Figure 2.

Factory Selection ..... PT100

### **2.3.5 MPU-16A SENSOR TYPE (S1-7, S1-8)**

Switches S1-7 and S1-8 configure the BPU-2A to match the MPU-16A sensor type. Selections available are: PT100, NI100, or NI120. See Figure 2.

Factory Selection ..... PT100

### **2.3.6 MPU-16A/STAND ALONE (W1)**

External jumper W1, between terminals 10 and 11, configures the BPU-2A for use with the MPU-16A or for stand-alone operation. Jumper W1 is installed for use with the MPU-16A and must be removed for stand-alone operation. See Figure 1.

Factory Selection ..... Installed (MPU-16A)

### **2.3.7 LATCHING/NON LATCHING (W2)**

External jumper W2, between terminals 5 and 6, configures the BPU-2A for latching or non-latching trips. Jumper W2 is installed for non-latching trips and must be removed for latching trips. See Figure 1.

Factory Selection ..... Installed (Non Latching)

## **2.4 BPU-2A/MPU-16A OPERATION WITHOUT A STATOR RTD**

If a stator RTD is not used, connect a 120-ohm resistor to the BPU-2A stator RTD terminals and enter the Mode-4 default values (trip 125°C, alarm 100°C) in the MPU-16A.

With no BPU-2A trips-or-alarms, the temperature display on the MPU-16A will indicate a temperature corresponding to the 120-ohm resistance.

## **3. INSTALLATION**

### **3.1 PANEL-MOUNT CONFIGURATION**

Outline dimensions and mounting details for the panel-mount BPU-2A are shown in Figure 3. The BPU-2A mounts in a 92-mm square cutout (1/4 DIN) and is secured to the panel by the panel-mount clamp. To mount the BPU-2A, insert it through the panel cutout and slip the panel-mount clamp over the BPU-2A body. Slide the clamp forward until the latch tabs snap into the mating holes. Lock the unit in place by tightening the four clamp screws against the mounting panel.

#### **--- CAUTION ---**

OVER TIGHTENING THE CLAMP SCREWS WILL DEFORM THE CLAMP AND CAUSE THE LATCH TABS TO RELEASE.

### **3.2 SURFACE-MOUNT CONFIGURATION**

Outline dimensions and mounting details for the surface-mount BPU-2A are shown in Figure 4. Mount the BPU-2A using M4 or #8 screws and external-tooth lockwashers.

### **3.3 TERMINAL BLOCKS**

Connections to the BPU-2A are made through two plug-in, wire-clamping terminal blocks. Each terminal will accept one #14 AWG conductor.

Terminal blocks are keyed so that supply voltage cannot be applied to the RTD inputs. The line-voltage terminal block has a keying pin blocking terminal 4.

### 3.4 RTD CONNECTIONS

The BPU-2A uses three-wire lead compensation which requires the three leads to a RTD to have equal resistance. This requirement can be met with shielded, three-conductor #18 AWG to #22 AWG cable. The RTD cable shields must be grounded at the BPU-2A only. The output cable to the MPU-16A must be grounded at the MPU-16A only.

### 3.5 POWER SUPPLY

The BPU-2A can be ordered for either 120- or 240-Vac operation. Connect supply voltage to terminals 2 and 3 (L1 & L2) as shown in Figure 1. In 120-Vac systems, L2 is usually designated as the neutral conductor. Ground terminal 1.

## 4. TECHNICAL SPECIFICATIONS

#### Supply:

120/240 Vac (+10%, -30%), 50/60 Hz, 5 VA

#### Environment:

Operating Temperature..... -40°C to 60°C

Storage Temperature ..... -55°C to 80°C

#### Output Relays:

Contact Rating..... 1 mA to 8 A Resistive,  
250 Vac or 30 Vdc.  
0.125 hp @ 120/240 Vac

Contact Configuration ..... Form A

Operating Mode..... Fail Safe or Non Fail Safe

#### Bearing-RTD Inputs:

RTD Type ..... 100-Ω Platinum (DIN43760),  
100-Ω Nickel, or  
120-Ω Nickel.

Lead Compensation ..... 25 Ω max.

Temperature Range..... 60°C to 120°C

Differential Range ..... 10° to 20°

Accuracy ..... ±3°C

#### Stator-RTD Input:

RTD Type ..... 100-Ω Platinum (DIN43760),  
100-Ω Nickel, or  
120-Ω Nickel.

## 5. ORDERING INFORMATION

**BPU-2A - P12 - 00**

Mount: \_\_\_\_\_

P Panel  
S Surface

Supply Voltage: \_\_\_\_\_

12 120 Vac, 50/60 Hz  
24 240 Vac, 50/60 Hz

Example: BPU-2A-P12-00 specifies a panel-mount BPU-2A Bearing Protection Unit with a 120-Vac supply.

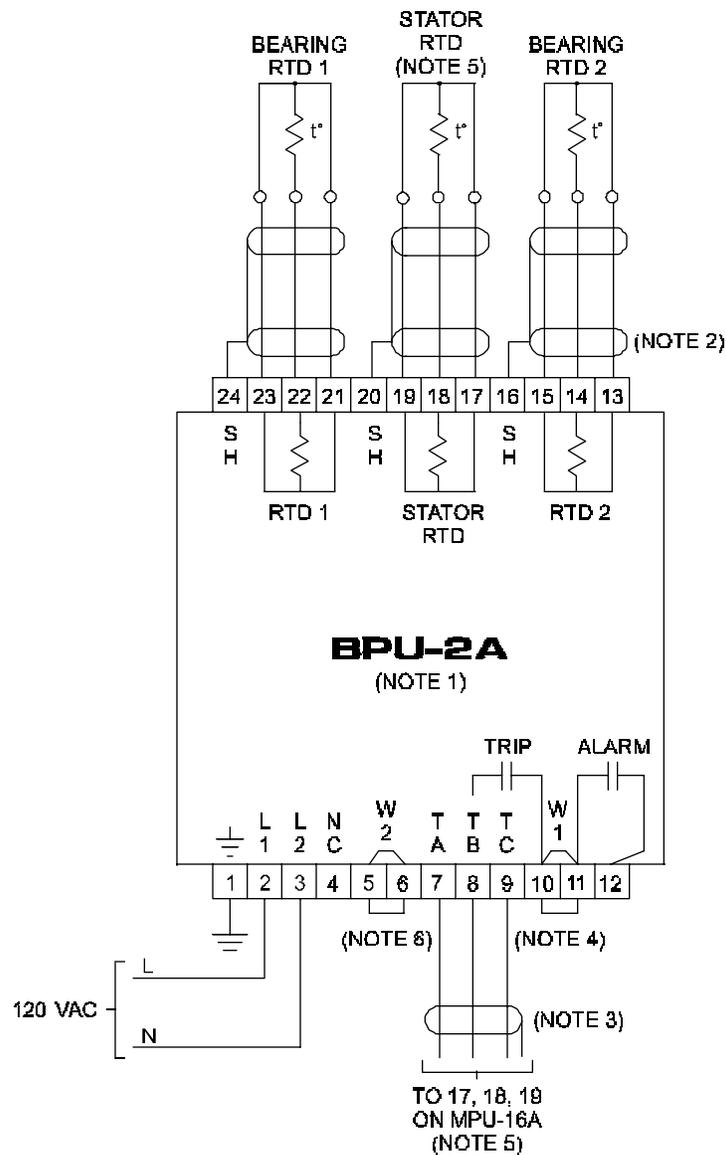

**NOTES:**

1. SURFACE-MOUNT CONFIGURATION SHOWN.
2. GROUND RTD CABLE SHIELDS AT BPU-2A ONLY.
3. GROUND CABLE SHIELD AT MPU-16A ONLY.
4. REMOVE W1 FOR STAND-ALONE OPERATION.
5. DO NOT CONNECT FOR STAND-ALONE OPERATION.
6. REMOVE W2 FOR LATCHING OPERATION.

**BPU-2A TYPICAL APPLICATION**

**FIGURE 1**

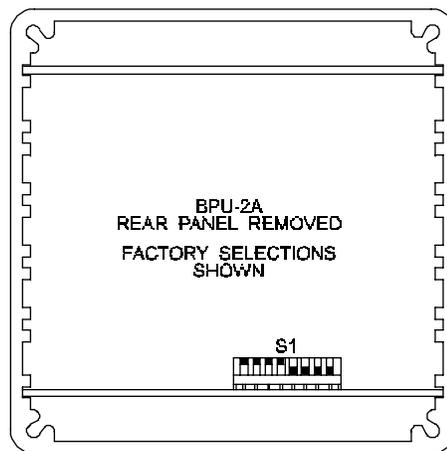
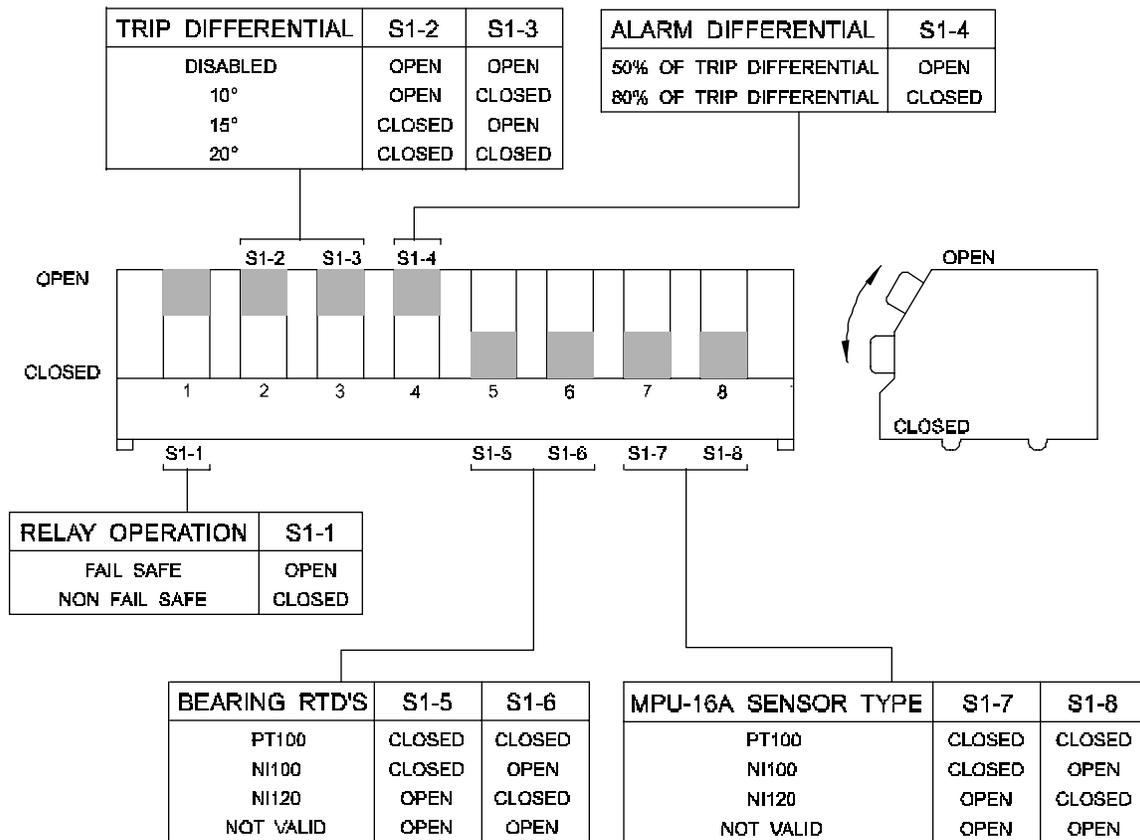

SWITCH LOCATION

**BPU-2A CONFIGURATION**

**FIGURE 2**

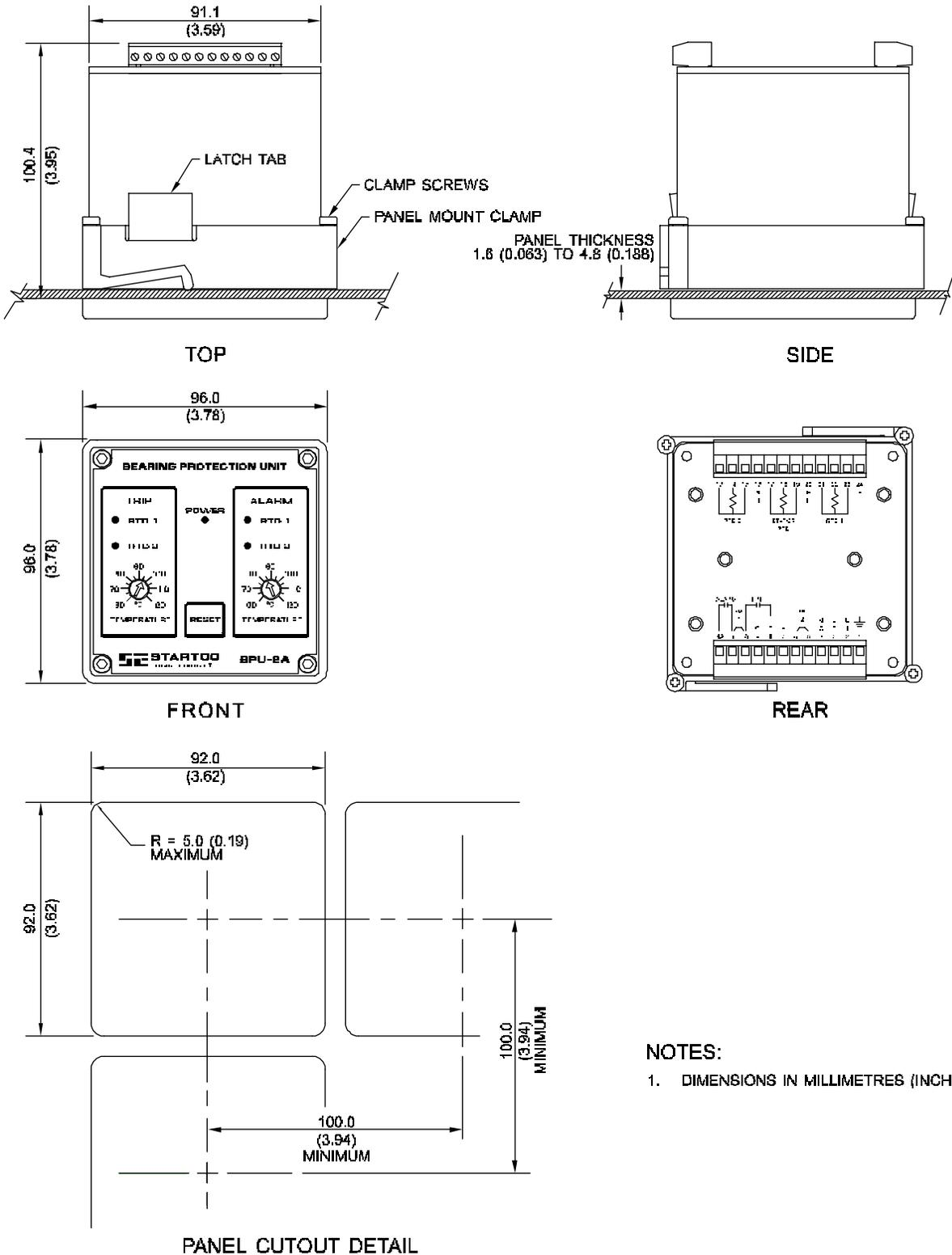

**PANEL-MOUNT BPU-2A OUTLINE AND MOUNTING DETAILS**

**FIGURE 3**

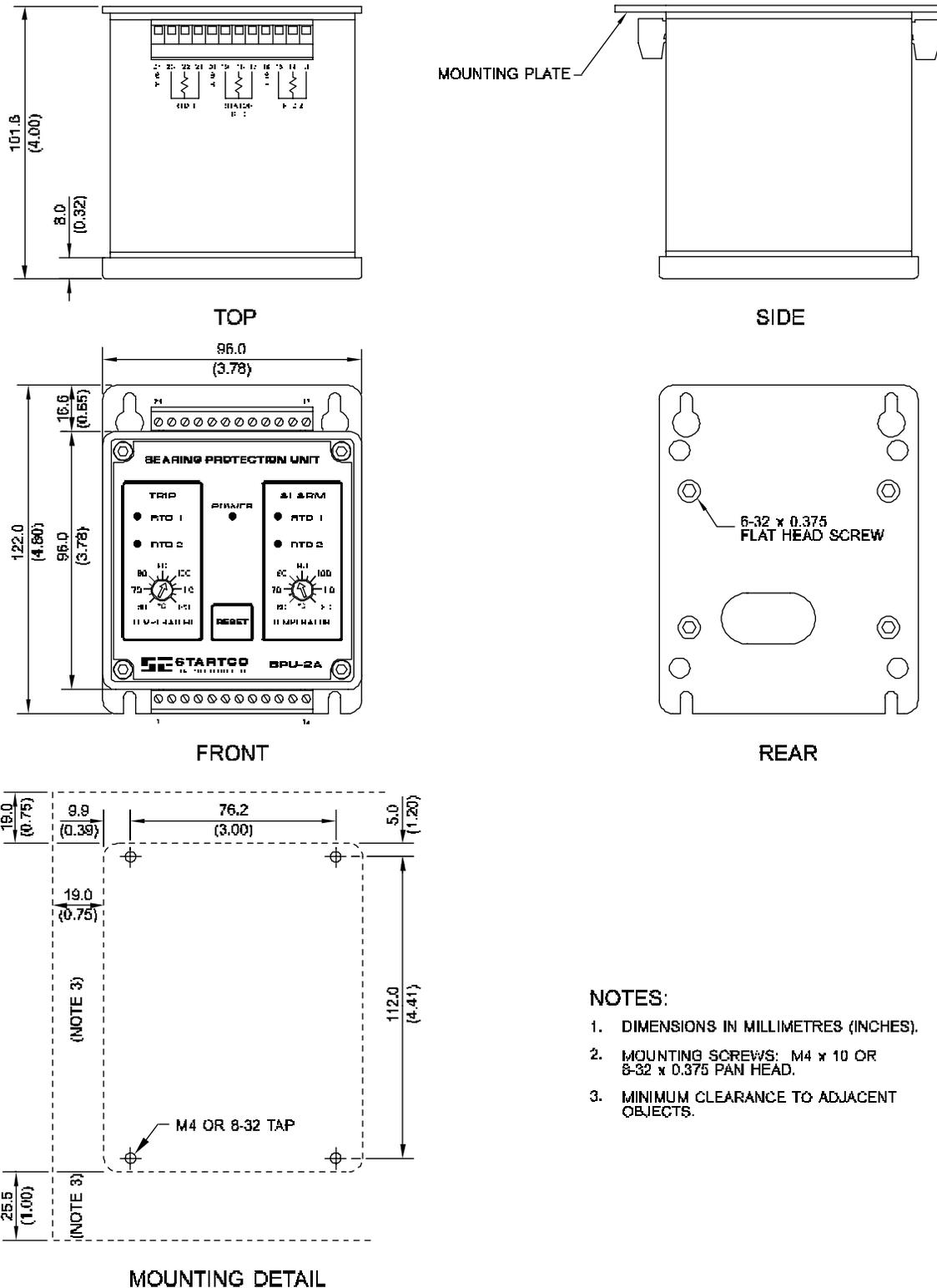

- NOTES:**
1. DIMENSIONS IN MILLIMETRES (INCHES).
  2. MOUNTING SCREWS: M4 x 10 OR 8-32 x 0.375 PAN HEAD.
  3. MINIMUM CLEARANCE TO ADJACENT OBJECTS.

**SURFACE-MOUNT BPU-2A OUTLINE AND MOUNTING DETAILS**

**FIGURE 4**